

CAMPING

South West Africa
1960's

Downloaded from:
“The Dump” at Scoutscan.com
<http://www.thedump.scoutscan.com/>



Editor’s Note:

The reader is reminded that these texts have been written a long time ago. Consequently, they may use some terms or use expressions which were current at the time, regardless of what we may think of them at the beginning of the 21st century. For reasons of historical accuracy they have been preserved in their original form.

If you find them offensive, we ask you to please delete this file from your system.

This and other traditional Scouting texts may be downloaded from the Dump.

Downloaded from:
“The Dump” at Scoutscan.com
<http://www.thedump.scoutscan.com/>



Editor's Note:

The reader is reminded that these texts have been written a long time ago. Consequently, they may use some terms or use expressions which were current at the time, regardless of what we may think of them at the beginning of the 21st century. For reasons of historical accuracy they have been preserved in their original form.

If you find them offensive, we ask you to please delete this file from your system.

This and other traditional Scouting texts may be downloaded from the Dump.

OUTDOOR CODE

OF THE BOY SCOUTS OF SOUTHERN AFRICA



1. I WILL TREAT THE OUTDOORS — OUR VELD RIVERS AND MOUNTAINS — AS A HERITAGE TO BE CHERISHED AND PROTECTED AND TO BE ENRICHED FOR OUR OWN ENJOYMENT AND FOR FUTURE GENERATIONS.
2. I WILL LEARN TO UNDERSTAND NATURE AND HER WAYS.
3. I WILL LEARN HOW TO PRACTICE CONSERVATION OF SOIL, WATER, FORESTS GRASSLANDS AND WILD LIFE AND URGE OTHERS TO DO THE SAME.
4. I WILL TREAT PUBLIC AND PRIVATE LAND WITH RESPECT, REMEMBERING THAT THE USE OF THE OUTDOORS IS A PRIVILEGE -
5. I WILL PREVENT FIRE - AND BUILD MY OWN FIRE IN A SAFE PLACE, AND BE SURE IT IS OUT BEFORE I DEPART.
6. I WILL KEEP MY TRASH AND GARBAGE OUT OF SOUTHERN AFRICAN WATERS, FIELDS, WOODS, VELD AND ROADWAYS
7. WHENEVER I TAKE FROM NATURE I FOR MY OWN USE, I WILL ENDEAVOUR TO RETURN A SHARE OF HER BOUNTY.

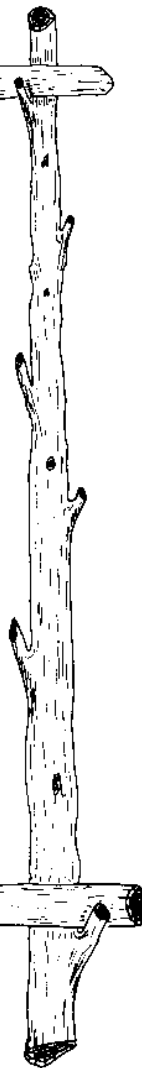

CAMPING

A HANDBOOK FOR SCOLTERS
AND PATROL LEADERS, WITH
PRACTICAL NOTES ON CAMPING
IN SOUTH WEST AFRICA

BY

RADISH RADMORE
DEPUTY CAMP CHIEF S.A. TRAINING TEAM
SOUTH WEST AFRICA AREA

THE OFFICIAL CAMPING HANDBOOK
FOR BOY SCOUTS IN SOUTH WEST AFRICA

THIS BOOK MAY NOT BE REPRODUCED IN FULL
OR IN PART WITHOUT WRITTEN PERMISSION OF
HEADQUARTERS OF THE ROY SCOUTS OF SOUTH
WEST AFRICA, P.O. BOX 2004, WINDHOEK, 9000

THIS BOOK IS DEDICATED TO
MY WIFE STIENIE,
AND SONS IAN AND COLIN,
WHO DO ALL THE JOBS
I SHOULD DO, WHILE
I DO SCOUTING

Printed in South West Africa by :
BOY SCOUTS OF SWA
P O BOX 200
WINDHOEK
9000

ACKNOWLEDGMENT

This book is offered to the outdoor fraternity in the hope that all may learn or expand their knowledge and appreciation of the great outdoors.

Many of the methods and material have been gathered I run thirty five years of personal experience in Scouting, twenty five of those years in South West Africa.

This opportunity must not pass without paying tribute to Scouting and Military colleagues over many years, too many to name or remember, whose ideas and comments have been of great value In formulating my approach to camping. Many ideas have come from authors of similar books, whose writings on woodcraft have been a guide and stimulus to Youth Leaders everywhere. Many of these authors, no doubt, also borrowed and developed ideas expressed by the original pioneers of woodcraft writings to such an extent that the original authorship is unknown. To them all I pay tribute.

As I am not at all artistic I have taken the liberty of copying many illustrations from books and magazines on the subject, over many years, and do not know who the original artists were. Some sketches have been taken from "Veld Lore" and from "Camping Standards for South African Conditions", both official Publications of the Boy Scouts of South Africa. To the original artists my sincere thanks.

There will be no financial gain to myself or the Scout Movement from the sale proceeds of this book. The only gain will be a better understanding and appreciation of the subject by our Youth and Youth Leaders.

With the above in mind, I wish to express my sincere thanks to all who knowingly or unknowingly; directly or indirectly gave such valuable assistance in the writing of this book.

CONTENTS

FOREWARD

INTRODUCTION

1. THE SECRETS OF SUCCESS
2. PREPARATION FOR CAMP.
3. THE CAMP SITE
4. SECURITY MEASURES.
5. DEPARTURE TO CAMP
6. ARRIVAL AT CAMP.
7. CAMP COURTESY,
8. TENTS AND TENT PITCHING.
9. PUTTING UP THE REST OF CAMP
10. HEALTH AND HYGIENE..
11. THE CAMP KITCHEN.
12. MEALS AND MENUS.
13. DAILY CAMP ROUTINE
14. CAMPFIRE
15. STRIKING CAMP.
16. ADMN1SURATION.
17. SUMMARY
18. APPENDICES

FOREWORD

This book is written for the Scouter and Patrol Leader in particular, and for all other members of the Scout Movement who wish to learn the correct way to camp in South West Africa.

From experience i have found that to camp successfully and enjoyable one must start by laying a good foundation in respect or camping.

It is advisable to lead up to good camping by preparing in accordance with details given in this book, and to use the book as a reference book whenever discussing or planning for camp.

This book contains a wealth of information on the subject of camping; from preparation twelve weeks before camp until details still requiring attention one week after camp. If used correctly regularly, it should be very useful in preventing the normal pitfalls that befall most campers.

It is hoped that you will find the information contained in this handbook of real assistance and that, as a result, you will be encouraged to camp with an increased knowledge of the subject, and a greater confidence in yourself.

Real Scouting is 90% action, and it will be in the practical application of what this book contains that its chief value lies. Because of this it is hoped that, encouraged by its contents, you will go out and do things.

I wish you all happy and purposeful camping and Scouting. May this book help you towards the attainment of both.

CAMPING

THE GREAT

ADVENTURE

INTRODUCTION

Camping is what makes ours so different to any other Youth Movement -

Camping is what boys look forward to and is the greatest opportunity for giving the boys a thorough training in all aspects of Scout work.

A Scout's first camp must be a happy one else he will never enjoy camping and will seldom look forward to camping again. In all camps the Scouters and Patrol Leaders can make or break the spirit of the boys and will be the weakest leaders if they are not prepared to let themselves be guided by the Court of Honour while preparing for, and during the camp.

Camping can be grand fun when you learn the proper way to go about it. A little study, a little planning and a training camp for practical experience may make the difference between a camping holiday and a camping nightmare.

There are one or two dangers in camping, but woodcraft will teach you how to avoid the dangers and enjoy the benefits. Some dangers are: sleeping on the ground in damp clothes and bedding; exhaustion after a sleepless night due to an uncomfortable bed; or illness caused by badly cooked meals. No need to tell you the benefits - there are thousands of them.

WOODCRAFT

What is the meaning of this word? Just this: know the signs of the veld; the choice of camping places the burning properties of the different woods available locally; methods of purifying water; how to make camp beds and bush shelters; how to cook with or without cooking utensils how to build camp furniture; when to use specific types of cooking fires etc.

CAMPING - is a similar word but with emphasis on a detailed knowledge of camping. This knowledge cannot be gained from books alone. Here experience is the best teacher, and it is with this object in mind that this booklet is written as a guide to campers seeking more experience. It should be the aim of every Scout to gain that experience at the earliest possible age. In this country there is no limit to scope. Here we can camp through out the year in sunny conditions and beautiful surroundings in the most ideal camping country in the world.

Camping teaches us quicker than ever how to **“ROUGH IT SMOOTHLY”**. Sleeping on the ground is no hardship to a South West African; hiking for kilometres is still less of a hardship, and sleeping in the open under our starry skies is a pleasure few people in other countries can enjoy. Making camp furniture or **“gadgets”** is not an art, but a **“natural”** to us, and veld cooking is just no problem at all. **ALL THIS WILL COME NATURALLY IF WE JUST SET ABOUT CAMPING THE CORRECT WAY.**

In an attempt to detail the requirements of a good camp the following information is given in this Camping Manual:

As with everything else in life there is a correct and an incorrect approach to an event. The incorrect approach is too often the rule, and the result is an unsuccessful camp.

The following nine points are very important if camp is to be a success:

1. Pro—camp training.
2. Preparation.
3. Organisation.
4. Punctuality.
5. Programme planning.
6. Duty rosters.
7. Visitors Day.
8. Security arrangements.
9. Swimming at Camp.

1

THE SECRETS **OF SUCCESS**

PRECAMP TRAINING

Boys should not camp until they have done pre-camp training. At indoor meetings bedmaking can be practised, fires can be packed (not lit) and tent pitching instructions revised. At outdoor meetings practical tent pitching, gad get making, wet and dry sumps, proper trenching, etc can be done with the whole Troop participating. Don't forget to practise striking camp and loading vehicles.

PREPARATION

This is dealt with in detail in Chapter II. This is some thing not only to be discussed but to be got down to and started 1.2 weeks before camp. The an the spur of the moment camp is rarely a success.

ORGANISATION

Everybody should have a job, and more important, should know how to do the job. The Scoutmaster cannot and must not do everything. Patrol Leaders and Seconds must be given certain responsibilities, so that they too can learn.

A Quartermaster (P/L or ASM) should be appointed for smooth running of that important aspect of every camp — food supplies and equipment. A camp Treasurer should be appointed to collect camp fees and control expenditure, to pay ac counts, and assist boys in controlling their own pocket money at long camps.

PUNCTUALITY

This is important during all stages of camp

— preparation, departure, excursions during camp changing of pickets at night, cooks going on duty packing of equipment at end of camp and striking camp so that transport vehicles are not delayed.

PROGRAMME

A programme should be planned for camp activities and duties long before camp, so that every boy knows what he must do and when it is to be done.

Programmes must be elastic for certain items to suit the mood or spirit in camp. Mealtimes, lights out times, getting up times must be strictly adhered to throughout camp to facilitate smooth running. The Court of Honour must assist in the drawing up of programmes, menus etc., so that they can learn to plan and organise. Members of the Court of Honour usually know the boys in their patrols best, and can give valuable advice to the Scoutmaster in respect of the boys' choice of events for the programme. This all results in a good fun packed training programme at camp, keeping every boy happy. Work and play should be 50/50 in every camp programme. Test passing periods should be included, and new items should be included at every camp. Don't just do the same thing over and over again. The programme must be neatly printed or typed, and prominently displayed on the camp notice board for all to see.

DUTY POSTERS

These should be so planned that when one or two boys are on duty and the others are playing, boys on duty must know that they too will have their free time when someone else will be working.

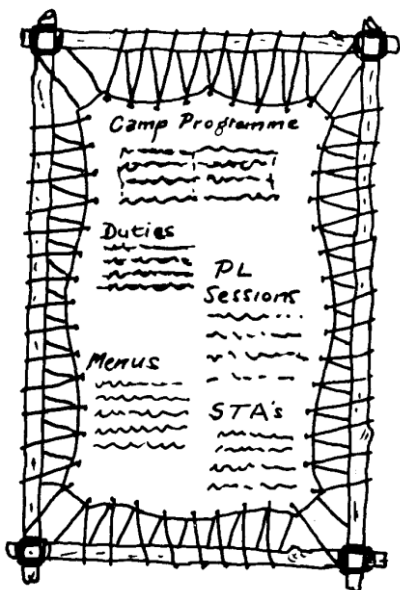

CAMP NOTICE BOARD

Every one at camp must have the same amount of work to do, not necessarily each day, but as long as the sum total of work done by each boy at camp balances out, there will be no complaints.

Don't overwork the inexperienced boys. Every boy when joining Scouts, has high expectations, and if made to do all the dirty work all the time at camp while others are enjoying themselves, he will quickly decide

that camping or Scouting doesn't appeal to him. Let each boy do his share of dirty work, but let that share be equal to that of all the other chaps in camp.

Duty rosters must be neatly printed or typed, and prominently displayed on the camp notice board for all to see.

VISITORS DAY

During a long camp arrange a day or afternoon when parents, members of other Troops, and any interested people can visit camp to see exactly what is done at Scout camps. Especially parents love to see what their boys do at Scouts. Camps are the best opportunity for this. Serve tea and biscuits and have a Patrol Leader allocated to each group of visitor else visitors will stand around aimlessly not knowing what to do. Have an early camp fire that night So that visitors can attend.

Camp must always be clean, especially on visitors day too, as such a camp is an ideal advertisement for Scouting.

Above all, do not encourage parents or visitors to drop into camp whenever they feel like it. Their visits at inconvenient times of the day can disrupt the programme, and many hours of valuable training time can be wasted this way.

SECURITY

Security measures must be borne in mind throughout the planning phase.

Gone are the days of carefree camping. A Scoutmaster must remember that he alone is directly responsible for the safety of his boys, irrespective of whether he is camping with them or having a routine Troop meeting. He must take all the necessary precautions to protect his boys whether it be against inclement weather, fire, accident, thieves or even the possibility of terrorist interference. Security will be dealt with in depth in another chapter in this manual.

SWIMMING AT CAMP

Scouts have a habit of going delightfully wild when swimming at camps, and very often caution is thrown to the winds

For this reason there are definite rules applicable to swimming and these rules must be adhered to at all times.

No Scout is allowed to swim, except under the personal supervision of the Scouter in charge of the party, or a competent adult swimmer appointed by him for the purpose (Rule 353 PO&R)

The safety of the place must have been previously ascertained, and all reasonable precautions must be taken, including the provision of an inflated inner tube or life ring, and a life line.

All reasonable precautions should be taken to ensure that swimming does not take place in waters infected with Bilharzia. (Often rivers flowing East)

A picket of two good swimmers, preferably those with Rescue Badge must, be on duty (undressed), in a boat or on shore, ready to help any boy in distress. The pickets themselves may not swim until the other swimmers have all left the water.

If camping near the sea, and the swimmers will be swimming in the sea, the Scoutmaster must first ascertain from local life savers or other authorities, where the dangerous areas are, and the general direction of current flows, low water and high water times, etc. Dangerous areas must be avoided. Limits must be established, e.g. nobody allowed to swim in water deeper than shoulder height, etc. A picket of 2 good swimmers must be appointed even if there are other lifesavers on duty. All the other rules mentioned above apply

Boys forget the intensity of the rays of the sun in SWA, even on a cloudy day. Avoid sunburn by insisting on the use of suntan lotions if the boys are not used to sun, and limit their swimming hours to prevent sunburn.

PREPARATION**FOR CAMP**

This previously mentioned –Secret of Success is really the key to all successful camping. Without preparation, camps are a waste of time, and without Patrol Leader and C.O.H. co-operation in the planning phase of a camp, preparation too is a waste of time.

There are four types of camps:

1. A Hike Camp.
2. A weekend Camp.
3. A Long-weekend Camp.
1. A Long Camp.

A HIKE CAMP is when two or three Scouts plan a walk from one place to another a few kilometres distant, spending one night in the veld enroute. This type of camp is one that also calls for careful preparation.

Unnecessary pots and pans and tin cans are not carried along, and the boys must make do with tin foil for cooking, frying, baking and boiling as well as for plate, plaster cast mould, enlarged reflector for torch when requiring more light, etc. One roll of tin foil has a multitude of uses in a hike camp, or any camp for that matter.

Tents are seldom carried along on hikes. This form or camp gives a Scout experience in making bush shelters, grass shelters, ground sheet shelters or just sleeping out in the open. A minimum of equipment is taken along and the Scout learns to improvise as much as possible.

No Scout should attempt a hike without previous training, experience and planning. Camp preparation involves training and experience plus planning of rood lists, weight of equipment, water point's enroute, survival

kits, miniature first aid kits with the minimum of requirements, preparation of log books and mapping equipment and countless other things that are essential to hiking. Accuracy of compasses should be checked before departure. Items like dry fuel tablets, water purifying tablets and emergency equipment should be taken along.

It is desirable that an inexperienced boy be taken along by more experienced hikers as a member of their party, on at least two hikes before he be permitted to hike with a less experienced partner. Even then he will still require much guidance and training before he will become a successful hiker.

A WEEKEND CAMP is usually a Patrol camp and is best left to the Patrol in Council if the Patrol Leader has had sufficient experience. The Patrol Leader should first have camped as a member of previous Patrol camps and have attended a Patrol Leader's training camp before he can run a Patrol camp.

In general a Patrol camp is similar to a hike camp as far as much of the preparation and equipment is concerned, but catering is done on a larger scale and many training stunts and fun are included.

Patrol Camps should be encouraged as these soon train a Patrol Leader to organise and lead correctly to accept responsibility and thereby become self confident. A Patrol seldom respects a Patrol Leader until he has proved to them that he can lead and look after them under all conditions. A Patrol Camp gives the Patrol Leader such opportunities.

Do not apply only ~~hike camp~~ preparation when planning a Patrol Camp. You will meet with disaster if you

do. Preparation for all overnight camps is similar.

A Patrol Camp is held as often as possible.

A LONG-WEEKEND CAMP is usually in the form of a Troop Camp held once or twice a year. This type of camp must be carefully planned by the Scouters and Court of Honour and the preparation for such a camp is similar in all respects to that of a long camp". So when reading the description of a long camp applies all details to a long-weekend camp".

A LONG CAMP is any camp of longer duration than a long-weekend. Here the man who does not plan well in advance is a criminal. Every little detail must be discussed and planned by the Scouters together with the Court of Honour, and each Patrol Leader must know every detail of the planning from the start.

For this type of camp a Quartermaster is a key man, and must be appointed. He can be an Assistant Scoutmaster or Patrol Leader but not a Scoutmaster as the Scoutmaster will have far too many other tasks in camp. A Camp Treasurer can be appointed to collect camp fees and deal with matters of finance, and he and the Quartermaster must co-operate throughout.

Applications must be made to your District Commissioner if your camp is to be held outside your own District, twelve or six weeks before camp, depending upon the type of camp. The District Commissioner will contact the D/C of the District where you intend camping, on your behalf. When once this contact has been made, bear in mind that you have brother Scouts near your prospective camp site, who can give you first hand information on the site, fresh milk and vegetable supplies etc.

When once you have decided upon the type of camp you intend having start a

CAMP BOOK, preferably of the loose leaf type, which should contain the following sections:

LIST OF CAMPERS - showing names per Patrol and Scouters.

DAILY SECTION - Showing

- A) Programme.
- B) Menu and food quantities.
- C) Cooks- names for each meal
- D) Duty roster - showing wood collectors, water carriers, hygiene team, duty Patrol, etc.

QUARTERMASTER SECTION-showing

- A) Groceries, milk etc., ordered beforehand and to be delivered on specific dates with names and addresses of suppliers and prices quoted.
- B) Notes on quantities of food supplies — excesses or shortages, completed at actual camp.

GENERAL NOTES

- A) Notes of things that went wrong.
- B) Record of Badges gained.
- C) Reminders of things that could be better planned ~~next~~ "time".

CAMP FIRES - programmes of all campfires held.

COMPETITION POINTS - the points system" if used can control a friendly spirit of rivalry at camp

NOTES FOR THE TROOP LOG - in case we have a bad memory.

DETAILS OF WIDE GAMES AND STUNTS.

COPIES OF ALL NOTICES APPEARING ON CAMP NOTICE

COPIES OF ALL NOTICES SENT TO PARENTS.

LIST OF TROOP, PATROL AND INDIVIDUAL EQUIPMENT taken to camp, with notes made at camp on equipment which was not required, and that which was forgotten.

CASH RECORD noting every cent collected (in the form of camp fees), and spent. This assists you in costing your next camp and also gives the details you will require when submitting a financial statement to your Group Committee afterwards.

PARENT CONSENT FORMS - an envelope pasted in will suffice to file the forms in.

SITE MAP showing details of lay out, prevalent wind directions etc.

POST MORTEM- notes on required improvements for future Camps.

The above seems lot of red tape, but when Troop camps are held the information is absolutely essential for the sake of continuity. Any new scouter joining your Troop will know at a glance exactly what to do when planning a camp. An inexperienced Patrol Leaders will be able to gather a great deal of information from the Troop Camp book when planning their call Patrol camps. The whole Troop gains by detailed recording of a planning in preparation for and during camp. With the ~~—~~skeleton“ Camp book ready K —skeleton” because 50% of the information

is added just before and during camp), start following a planning programme for a long camp (or figures in brackets for shorter camps) as follows:

PERIOD BEFORE CAMP	JOBS TO BE DONE	BY WHOM	PERIOD BEFORE CAMP	JOBS TO BE DONE	BY WHOM
12 Weeks (6 weeks)	Select site, have general discussion, write or visit owner to obtain permission. Visit site as soon as possible after above. If site is acceptable plan layout, draw map and send preliminary notice to parents. Advise District Commissioner,	Court of Honour and Scouters	6 Weeks (3 weeks)	Send notice to parents giving full details of site, cost, dates, objectives of camp; and attach consent forms.	Scout-master
				Arrange Security guards (parents) armed, for day and night duty.	Scout-master
			4 Weeks (2 weeks)	Receive consent forms back from parents.	Scout-master
8 Weeks (4 weeks)	Discuss what has been done; obtain estimate of number of boys and Scouters attending; discuss theme of camp	Scout-master		Finalise food lists	Quarter-master
				Make transport arrangements (vehicle or train)	Asst Scout-master or Transport Officer of Committee
			Quartermaster prepares food lists on basis of food per person to allow for alteration.	Quarter-master	
Enquire re places of interest near camp and doctors' addresses etc.	Court of Honour		Make transport arrangements to and from train if applicable	Asst Scout-master or Transport Officer	

PERIOD BEFORE CAMP	JOBS TO BE DONE	BY WHOM
4 Weeks (2 weeks) Cont.	Prepare stunts, competitions, surprise items.	Scouters
	Prepare List of Troop equipment	Scouters/ Court of Honour
	Check First Aid Box	Asst-Scout-master
3 Weeks (2 weeks)	Discuss above, and more or less complete camp book	Court of Honour
	Obtain permit from District Commissioner.	Scout-master
	Visit campsite for final lay out details.	Scouters/ Court of Honour
2 Weeks (1 week)	Visit –difficult? parents	Scouters
1 Week (1 week)	Check transport arrangements with Transport Officer of Group Committee	Asst-Scout-master
	Check food deliveries etc. with suppliers	Quarter-master
	Pack Troop and Patrol equipment.	Troop, with Asst, Scout-master Supervising

PERIOD BEFORE CAMP	JOBS TO BE DONE	BY WHOM
	Rucsac inspection checking contents of each camper's rucsac	Partol - Leaders
2 Days	Obtain clean bill of health from every one	Asst. Scout-master
Day of departure and arrival at camp	Asst. Scoutmaster in charge of Troop and _transport	Asst. Scout-master
	Upon arrival QM visits shopkeepers to check deliveries (if applicable). Scoutmaster visits owner of ground where camp is to be held. Apart from this one job Scoutmaster is free to supervise generally It is advisable to visit the local doctor to tell him where your site is and to ask him to visit your camp once or twice.	Scout-master

PERIOD BEFORE CAMP	JOBS TO BE DONE	BY WHOM
During Camp	Constant Checking of menus, food supplies, wood supply, water supply, condition of equipment, quantity of equipment, first aid kits, condition of tents, maintenance to tents and equipment etc.	Quarter-master
	Constant checking and preparation of events on programme and note down all changes to programmes, duties, etc. with reasons for change; mood and atmosphere of campers so that programme can be changed if essential; security matters; keeping the campbook written up to date and note made of possible future improvements, etc. It is important that shortcomings are mentioned here, and surpluses also noted.	Scout-mater, Asst. Scout-master, Troop leader

PERIOD BEFORE CAMP	JOBS TO BE DONE	BY WHOM
	Constant check on camp programme, duty roster's, etc., so that preparation of equipment etc., is timeously done for events. Also of patrol equipment to minimise losses, damage, injury; and Patrol Logbooks brought up to date	Patrol Learders
Day of Departure from camp	Basically the same as —day of departure to camp” except that	Assy scout-master
	Scoutmaster goes to thank owner of ground, and any others that assisted to make the camp such a success.	Scout - master
	Check all equipment to make sure nothing is lost, or dirty.	Quarter-master

PERIOD BEFORE CAMP	JOBS TO BE DONE	BY WHOM
Arrival back at H,Q	Pack equipment in store. Make sure wet or damp tents and ropes are put out to dry. All perishable foods to be removed from food boxes and disposed of. All returnable foods returned to supplier for credit.	Quarter-master
	Accounts paid and finances finalised	Treasurer
First week after camp	Court of Honour meeting to do the following: a. Post Mortem on camp so that any problems can be analysed to prevent future repetition: to generally discuss success of camp; future requirements, etc	Scaout-master Asst. Scout-masters, Quarter-master, C,O,H members

PERIOD BEFORE CAMP	JOBS TO BE DONE	BY WHOM
	b.Finalisation of Camp Book so that an updated copy is filed as a future reference piece when other camps are planned. c.Records brought up to date camping record, badges and awards records, etc d.Letters of thanks sent out to all lay persons who assisted to make the camp a reality. e.Revision of training to improve standards where necessary	
First troop Meeting after camp	Badges and Awards gained at camp, awarded to recipients	Scout-master
	Final cleaning, sorting, maintenance and packing away of camp equipment	Whole Troop under the guidance of Q.M
3 weeks after camp	Start preparation for next camp:	SM,ASM's Q.M & C.O.H

If you plan according to the above programme you need have no fear in respect of the success of your camp. Have a "Post Mortem" after camp to discuss matters that could be improved when planning the next camp.

A Camp Book does not have to be drawn up for hike camps, but can be prepared in a broad sense by Patrol Leaders as part of the preparation for their Patrol Camps. the Camp Book must, how ever, be prepared for every Troop Camp, whether it be a weekend camp, long camp or long-weekend camp, and any other camp, tour or excursion or two day duration and longer.

The following books can be read for further hints on camping, hiking, sleeping bags, tents, etc.

"The Scout Trail"

"Camping Standards for South African Conditions"

"The South African Backpacker"
by Helioke Hennig.

"The Boy Scouts Camp Book"
by Philip Corrtngton.

"Cook and Master Cook" -Scout Badge Test Series No. 6

"Outdoor Cooking" by Lone Wolf

"Backwoods Cooking" -Patrol Book No. 17.

"The Patrol Leaders Handbook"
(Chapter 7) by John Thurman.

"Scout Camps" by John Thurman
(for Scouters)

"The way to camp" by S.H. Walker

"Standing Camps"

"Woodcraft Way"

As many of these books as possible should be read by Patrol Leaders and Scouters.

Many of these books were written to meet camping conditions in Europe and must be adapted to South West African camping conditions.

There are many more camping book on the market that can be read before going to camp - make use of them all. Books on camping and any other training manuals should be taken to camp. A camp Library should be established so that boys can refer to books on camping and other training aspects.

The reading of books on camping is essential parts of the preparation for camp but remember that only practise makes perfect.

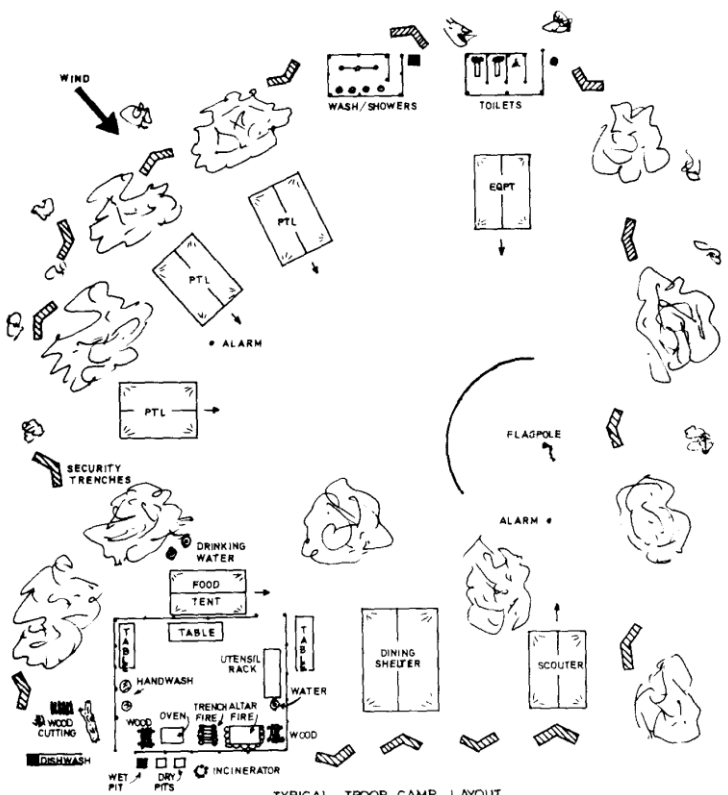

TYPICAL TROOP CAMP LAYOUT

3

THE CAMP SITE

Consider choice of campsite to be the next most essential after thorough preparation for camp.

For a hike camp or one night camp, almost any piece of ground will suffice, but longer camp requires a great deal of site planning.

The ground must be as level as possible with as many trees as possible. The grass should be short and the area should not be too stony. Neither should it be too sandy. Areas where cattle previously congregated should be avoided as ticks and tampsans will abound there.

Avoid river beds as that invitingly soft sand in the day becomes the coldest and hardest bed at night. If you wish to camp near water, avoid stagnant pools or mosquito infested dams and reservoirs and stay away from muddy pans where mud turtles and "lkswaans" (leguan) often lurk.

Keep clear of hollows where water can collect in the rain season. Don't camp where there are many blackjacks, "steekgras" or thistles (bloudissel) or nettles. They make camp life uncomfortable.

Let COMMON SENSE be your guide when choosing a camp site. Choose a shady spot in summer and a warmer spot in winter, but where possible amongst trees, as shade is as necessary in winter as in summer in this country.

Avoid dense patches of trees or bush in the rainy season as it remains wet for long periods. If possible have a site where

a large open piece of ground is available for games, training etc –

Before a dense area is used as a campsite, make doubly sure that there are no snakes in the bushes or trees. Avoid areas where there are snake holes and meerkat holes.

The ground must be hard enough to hold a tent peg and soft enough to dig a 50cm refuse pit in. A gravelly soil is most suitable - good drainage no dust and little grass. Avoid clay.

Wood and fresh water should be close at hand and the site should not be too far from a bush track. Avoid camping near to main roads as constant traffic movement and dust is a nuisance.

Animals can be a nuisance if their footpaths run through your camp, or their feeding place is nearby. Avoid this. Don't have a fence running through the centre of your campsite.

If possible, camp a few hundred yards from a house with a telephone in case of emergency. If other trees are available avoid camping under Kameeldoring trees as ticks and tampsans abound there. The ground under these trees can be sprayed with dieseline 2 weeks before camp to kill the ticks and tampsans.

4

SECURITY MEASURES

Scouting is a peace - loving non - political, movement. Parents will believe that if there is any danger involved in Scouting their boy should not be exposed to such dangers.

We should thus not be alarmists, but we must definitely be realistic. Our motto "Be Prepared" tells us to be prepared for anything at any time.

Parents should be made to understand that irrespective of where their boy goes he will be exposed to dangers, but that Scout camps and meetings are virtually the only places where the boy's safety is properly catered for.

The application of security measures is a way of life we all accept in South West Africa, so there should be no need to motivate parents in this respect.

The Group Scoutmaster must ensure that security measures are applied throughout his Group. At Scout Troop level the Scoutmaster is directly responsible for the safety of his boys at camps and meetings, but must be assisted by parents in this essential task. The Scoutmaster alone cannot accept this responsibility. Parents of Scouts and other interested persons must assist with implementation of security measures at camps, Troop Meetings, etc If such assistance is not forthcoming, the Scoutmaster must not allow camping or outings. However this action may be to the boys, Scoutmasters must be firm in this respect. "No security - no camp" must be the rule.

Parents must assist with sentry duty at camps during the day and during the night.

Scouters are so busy during day programme that they cannot possibly watch their surroundings at the same time all the time.

The main reason for security sentries at camps is to intercept intruders or where there are definite indications of pending danger, to warn the campers so that they are not surprised. One or two parents during the day are required. Their specific task is to sit in inconspicuous places, apart, and to watch the areas beyond the perimeter of the camp. Strangers in the area must be confronted and if they have no reason for being in the area, told to leave the area. This action must however, be discussed with the landowner before the camp.

At night at least two security sentries are required, and should not be expected to work throughout the night. Fresh security sentries should commence duty every 4 hours at night.

It is not compulsory that security sentries must be armed, but it is preferable, on condition that the sentry is an adult and that he or she is an experienced user of a firearm. A rifle or shotgun, or semi automatic weapon is useful, but if nothing else is available a handgun will suffice. All the normal safety precautions in respect of firearms must be applied. A person approaching the camp or Troop Hall or any where else where security sentries are on duty must not be shot at as this is itself is a serious offence. The person must be told to halt and must be asked what the purpose of his visit is. He should be told to leave the area if he does not have a valid reason for being there. If the visitor is carrying a firearm or handgrenade or similar explosive item, and makes a

serious attempt to use the item when challenged by the security sentry, the sentry must decide for himself whether to shoot or not, depending on whether anyone else's life is in danger.

Boys, irrespective of their age, may not take firearms to camp or on hikes - They should participate in security sentry duty at night, but must be accompanied by an adult security sentry at all times.

There must be no lights or smoking by parents at the security points at night.

Sentry points must be alternated every day and must never be in the same place on any

two consecutive nights. Routes to be followed by relieving sentries must be clearly defined and known to all sentries every night so that the sentry point is approached from only one direction.

A password system based on challenge and answer must be introduced, with a different word every night e.g.: challenge - "egg" and whispered answer - "flip"

Security trenches, although not compulsory, are definitely commended for standing camps when there is doubt about the safety of the area. Trenches should be approximately 50cm deep and approximately body width.

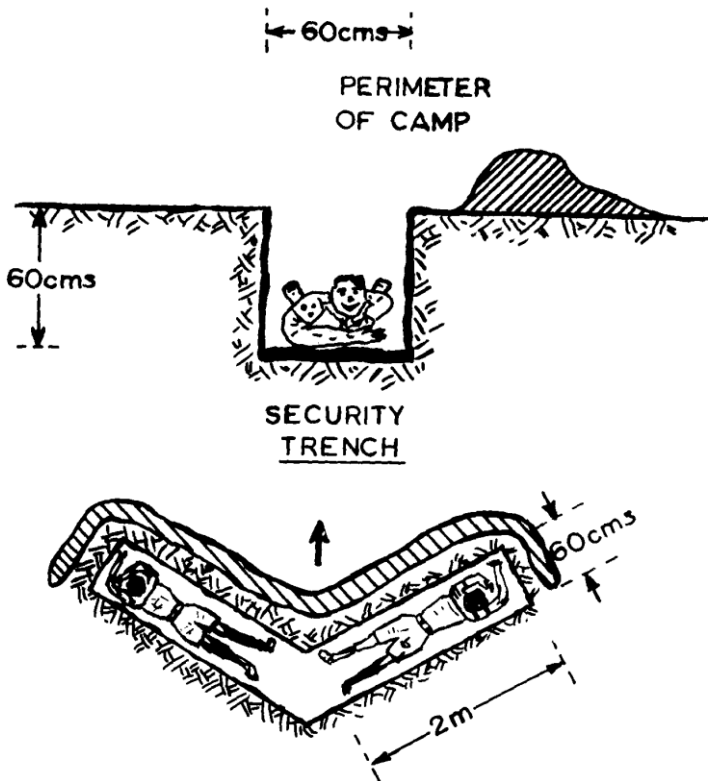

These should be dug even before tents are pitched or kitchen built. Where the ground is too stony, sand bags or ordinary sand filled grain bag can be used to make 50 cm high shelter walls

All persons must discipline themselves to place to place shoes and a minimum of clothes ready at their bedside for quick use at night. Lights must not be used clothes or to dress, or to fang your way to shelter

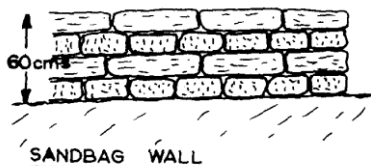

At camps where there is doubt about safety of the area. trenches should be dug or sand bags positioned near the straining or games area if they are far from the trenches near the sleeping tents. Alternately, when far from shelter the rule must be to fall flat and remain flat with face towards ground immediately the danger signal is sounded

Emergency signals must be known to all as follows:

- A. Continual short blasts on whistle means all assemble at H.Q. (in case of fire etc)
- B. One long continual blast on whistle means "freeze" Everybody to be absolutely quiet and to stand dead still where ever they may be. Instructions might then be given. Nobody to move or make any sound until "defrost" -one single sharp blast on Whistle is sounded.
- C. Repeated short—long, short— long blasts on whistle indicates danger. All persons must immediately but calmly evacuate camp. Everybody moves as rapidly and quietly as possible (without lights at night) to trenches or sand— bagged shelters, if shelters or trenches have not been made, everybody moves to an area away from domestic area of camp, predetermined by the Scoutmaster at the commencement of camp. There every body lies down flat on their stomachs, faces down in their hands. Time must not be wasted in getting dressed or rescuing personal belongings or other items of equipment. Scouters and parents having firearms and ammunition must take these items with them. Persons responsible for first aid must take their first aid kits with them. Any mobile radio transmitters and loudhailers must be taken along. To prevent confusion it is important that responsible persons are pre— appointed to take the above items with them. Everybody remains in their trenches, or in shelters or on their stomachs until the "all clear" is sounded, or other instructions are shot by the Scoutmaster or next senior person.
- D. One single sharp blast on a whistle indicates "all clear" (similar to "defrost" signal). When the "all clear" signal is sounded after a danger signal was sounded, everybody must form up at H.Q. immediately so that roll—call can be done.

All the above emergency signals must be practised regularly. Persons must react immediately and the practise must not be

permitted to be treated as a joke. Discipline must be of an exceptionally high standard and commands must be executed without question or hesitation, Practise must take placer lights or smoking the sentry points so during day and night, and should preferably be done regularly at weekly troop meetings. The drills apply equally for Troop meetings or any other Scout events.

Once at camp, the emergency drills must be practised only once so that everyone becomes acquainted with the area to which they will evacuate. This must not be done at night and must be done within the first three hours of commencement of the camp. Thereafter there are no more practises at camp - all emergency signals are used only in the event of an emergency

Avoid routines at all costs. Breakfast, lunch and supper times must be changed daily and must not be routine. A good example of meal times is as follows:

DAY	BREAK-		
	FAST	LUNCH	SUPPER
a. Friday	07h00	12h15	18h30
b. Saturday	09h00	13h30	19h15
c. Sunday	08h15	12h40	18h00
d. Monday	06h30	12h00	19h00

Queues for food are to be avoided. Food should be dished up into patrol quantities if served from a central kitchen, and handed to a Patrol orderly. Each Patrol eats separately, but not inside tents. Patrol members sit in such a manner that some look outwards and others inwards Security sentries must be strengthened by addition of boys, and must be on duty during meal times.

During formal training, Scouts Own, campfires, and whenever boys are grouped together, there must be sentries outside the group looking outwards. Remember that during training sessions all eyes are towards

the instructor, looking, listening and concentrating in one direction only. Also during prayers all eyes are closed. Let two or three boys or sentries) keep their eyes open and be facing opposite directions

At night, have as few lights as possible on in camp, and if at all possible have powerful lights shining outwards from the perimeter of the camp. All persons should avoid moving directly under overhead lights, in Lit-areas or inside Lit-up tents. If permanent buildings are used at a campsite, avoid standing in lit-up doorways or windows. Draw curtains after dark. If no curtains are available attempt to put up other substitutes material.

Do not permit any strangers in or near the camp area. People walking into camp must be approached by an adult and asked their business. Strangers should not be left to wander away but should be escorted away to either the landowner's home or at least 2 kms away from camp. Under no circumstances must casual labour be employed in or near camp.

Visitors to camp must be restricted to predetermined dates and times, and all visitors must be positively identified by a Scout in camp.

When patrols or individuals are away from camp exercising, or on short hikes or expeditions they must have radio contact with the camp. If this is not possible due to lack of radios hike or expedition routes must be visually checked by Scouters or sentries at regular intervals.

During "visitors day" visitors vehicles must be parked at least 100m from camp. Have a sentry watching the car park and

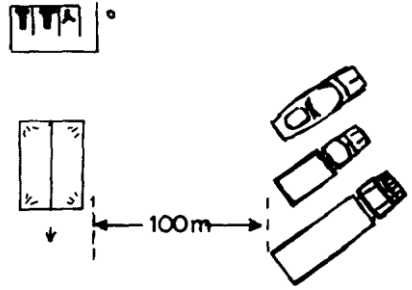
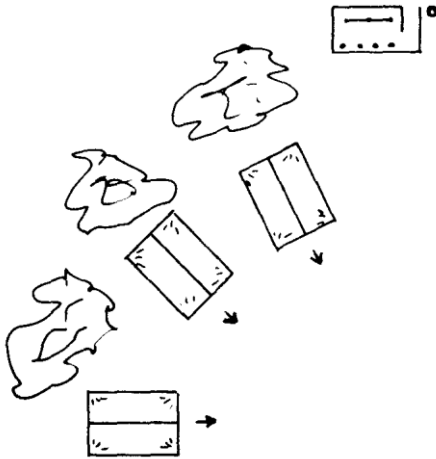

VEHICLE PARKING

double the day sentries. Do not permit visitors to return to their cars to remove objects to take into camp. If they have brought eats or anything else for the boys, these items must be removed from vehicles upon arrival.

The same parking rules that apply to Scout vehicles in camp, apply to parents on visitors' day. Cars are to be parked with noses in direction the vehicle will move out after the visit; ignition keys are to be removed by owners; vehicles must not park in such a position that they obstruct another vehicle's departure, etc.

Brief parents by means of circular letters in respect or security arrangements at camp so that they know what to expect; what to do upon arrival at camp; and above all, that their boy are being well cared for. Brief visitors in respect of action to be taken by them should the danger signal be sounded during their visit.

Remember –God helps those who help themselves”. If Scouts, boys and parents do not do any thing about security they should not expect only prayer and trust to save them

Security measures are a way of life in South West Africa. Any Scout, Scouter, or parent who ignores this way of life is a criminal in his own way, giving en enemy an opportunity to gain a moral victory or take an innocent lire, perhaps yours or mine.

It is impossible to think of every possible situation. This chapter is only food for thought. Read it and add your own precautionary measures where necessary.

And do not ever let the stringent security measures put us off camping and outings. We must continue with life as we know it, but we must also accept the fact that it is essential that we move about with eyes wide open end senses tuned to anything irregular so that we are never caught on the wrong foot.

Never run away from reality- learn to cope with circumstances as they are, and let's do it with a smile.

5

DEPART U RE

TO CAMP

All Scouts and Scouters leave for Camp in full uniform.

All equipment and kit to be taken to camp should be packed outside the Scout Den at a convenient place, ready for loading onto the vehicles, at least 15 minutes before the time of arrival of the vehicles.

All Troop and Patrol equipment should be packed in stout wooden crates or metal trunks labelled "Troop" or "Zebras" "Eagles" etc., and nothing small should be loaded onto the vehicles unless packed. Staves should be secured in patrol batches and personal kit packed in rucksacs or kit bags, labelled with the owners' name, and stacked in patrol batches. Any delicate articles like lamp glasses, etc., should be well packed. The First Aid kit should be stowed in the cab of the vehicle so that it is readily available.

When the vehicles arrive, only Patrol leaders and Seconds should be permitted on the vehicles to do the loading. All others pass kit to them. Try to allocate a vehicle to each Patrol. If there is only one vehicle, pack Troop equipment separately, Scouters' kit separately and all other kit in patrol batches on the vehicle. Loose items like torches, plates, shoes, etc., should not be permitted as these are the first things which get lost.

Once everything is stowed on the vehicle, allow the boys to embus, climbing on from the rear, not the sides. All persons on the back of the vehicle must sit flat.

Legs may not hang over the sides and nobody may stand or sit perched high up on the roof of the vehicle or on stacked equipment, or on the side piece. An Assistant Scoutmaster or Troop Leader or Patrol Leader must be on the back of the vehicle to supervise while travelling. Hats and berets must be secured so that they can not blow off, or removed before departure.

Scouts should report at their Scout Hall at least one hour before the programmed time of departure and vehicles must move off on time. Punctuality is very important. If departure is late the whole programme is delayed.

Scouters must satisfy themselves that vehicles are in roadworthy condition before departure (brakes, lights, etc.) and that the necessary authority has been obtained from the Local Road Transport Board or Traffic Department for the transport of persons on open vehicles, where applicable. The Transport Officer of the group Committee must ensure that vehicles are in roadworthy condition, but for control purposes the Scoutmaster must finally accept responsibility for condition of the vehicles.

6

ARRIVAL

AT CAMP

We have seen so many camps start off badly due to lack of preparation. Many camps get off to a bad start and remain that way just because the arrival at camp was chaotic, with Scouts running left and right, not knowing what to do.

Arrival at camp should be as calm an occurrence as taking an aspirin. Scouters should leave the Patrol Leaders to see to the unloading of vehicles and pitching of camp. Scouters give advice where necessary, but should not shout instructions left and right as this confuses everyone. If the preparation of camp was done correctly there should be no need to give instructions upon arrival at camp - each Patrol Leader should know exactly what to do.

You will recall that two weeks before camp the Court of Honour and Scouters should visit the campsite for a final inspection with a view to finalising layout details. They will then decide where each Patrol will pitch their tents, where the kitchen will be situated, where the latrines will be erected, where the grub tent will be pitched, where head-quarters tent and the Scouters' tent will be pitched, where water supplies will be stored, where wet and dry sumps will be dug, and very important - where the loading zone will be.

The LOADING ZONE influences smooth arrival at camp. It should be a spot where the transport vehicles can be halted in such a way that they can depart again without going through the centre of camp or driving round kit and partly erected tents.

The vehicles should be halted facing the direction of departure with the rear of the vehicle in the shade of trees if possible so that the kit can be offloaded in the shade. This is a recommended procedure:

- a. Vehicles halt facing direction of departure. All remain seated.
- b. When last vehicle has halted an Assistant Scoutmaster gives signal and Scouts debus at rear of truck. They do not Jump off at sides. This is important as vehicles often have to stop on main roads and boys jumping off at the side of a vehicle can be run over by oncoming traffic.
- c. Scouts form up off the road, or when in open spaces near the rear of the vehicles, and each P/L instructs his Patrol to form a chain from the rear of the vehicle to the Patrol Dumping Zone.

If vehicles are allocated on the basis of one per Patrol, each Patrol Leader and Second can off-load their respective vehicle while the chain of Patrol members dumps the patrol kit at each Patrol Dumping Zone. If one large truck is used to transport all the kit it will be better for the whole Troop to form a chain from the rear of the truck to one central spot where Patrol Leaders can sort each item of kit as it arrives, and have kit dumped in Patrol batches. In this case the Seconds should be on the vehicle to offload. Kit should also be packed on the vehicle in Patrol batches which simplifies the ultimate unloading task.

It is not a good idea for each Patrol to dump their kit at their Patrol campsite every time some thing is offloaded. This takes longer, delays the vehicle's

departure, and kit usually is in the way when tents are pitched.

Troop equipment and Scouters kit should be dumped in two separate batches when unloading.

- d. When all the equipment and kit is offloaded Scouts can change into camp clothes and then form up to commence digging trenches or making sandbag shelters. After completion of this task they are to be taken to their Patrol camp sites by their respective Patrol Leaders.
- e. If vehicles remain in camp they should be parked well away from kitchens and camp fire areas. No vehicle should be allowed in the camp perimeter and driving through camp is not permitted. All the vehicles should be parked together well outside the camp perimeter, and ignition keys kept by the Scout Master just in case of fire or other emergencies. Keys must be readily available in case of emergency. It is advisable to have at least one vehicle available at all camps in case of emergency.
- f. On no account must vehicles be permitted to drive all over the camp area delivering kit at Patrol campsites. This loosens the ground surface ultimately causing dust, and is dangerous to boys who in the general excitement of events, walk carelessly.

7

COURTESY

AT CAMP

So many of us feel so free and happy in the Veld that we forget courtesy - we don't only run free, we just run wild.

In camp we can relax, give vent to our feelings, wear what we wish at times, and run where we wish but a few words on camp courtesy should not be out of place now before we get down to real camping. Certain camp etiquette rules must be adhered to at camp, otherwise tempers might run high resulting in squabbles and dissatisfaction - the downfall of even the best organised camps.

Remember self control at all times - don't shout and scream - discipline (not military regimentation, though) is important.

Be ready to speak and act in an open and hospitable manner to all at camp. Insulting language and backbiting should not be tolerated, and any under current or dissatisfaction should be remedied immediately before the morale of campers is affected

Never leave gates open and never climb over gates or fences - walk through the gate, that is what gates were made for. Never ride on gates.

Don't trample or run through crops or vegetable patches; walk round the edge of the field.

Do not chase cattle, goats or any other animals, and wild animals or birds are never to be disturbed.

Never cut or chop into green wood or live trees and bushes. Use only dead wood.

Leave no litter on the campsite, not even sweet papers, string or matches. This should all be burnt in a camp incinerator or buried in the refuse pits made for that purpose.

The kitchen, food tent, and wet and dry sumps are ~~taboo~~ to all ranks. Only those on kitchen duty are permitted in the roped off area of a kitchen and food tent.

Meals are never eaten in sleeping tents. If a mess tent is not erected for the purpose a canvas awning or shady spot will be allocated for this purpose.



DINING SHELTER

No scraps of food or bones or bread crusts may be left lying around. Food is not to be kept in sleeping tents.

Plates and eating utensils must be washed at a spot allocated for this purpose. Water is scarce and if one dirty article is washed in a bucket of drinking water that water is wasted,

Never run round tents and vehicles; you can run to your heart's content in the open veld.

Do not loiter or play near latrines.

Never walk between other Scouts talking and never interrupt their discussion.

Camp must be quiet between the hours of ~~lights - out~~ and ~~rise - shine~~.

When Scouts leave the Camp to go to town or to entertain guests on visitors day, they must be in full uniform.

Camp raiding or Patrol raiding is forbidden as this usually ends with someone getting hurt.

All personal articles picked up must be handed to the Scoutmaster

Never criticise or take fun of another Scout's religion.

Show respect to all, but grovel to none at camp.

The Scout Law is the law of all Scout camps.

TENT PITCHING

Perhaps by now you have realised how much preparation is required before tents are pitched and the camp actually started. We have gone through seven chapters of preparation before even discussing tent pitching.

Upon arrival at the campsite, and after unloading trucks, Scouts change into camp clothes. Scouters indicate where trenches or sandbag shelters are to be dug or built and this task is completed before anything else is done. After completion of trench digging, Patrol Leaders take their Patrols to their Patrol camping sites where the ground should be cleared of high grass and stones. The ground where the tent is to be pitched should be a little lower at the door end of the tent if possible, so that rain water can drain away from the tent entrance.

See the sketch for tent terms.

A. PITCHING LIGHTWEIGHT TENTS (HIKE, PUP AND SIX MAN TENTS)

One or two boys can pitch this type of tent with ease.

1. Decide exactly where the tent is to be pitched and establish the direction of the wind.
2. Lay out the tent fabric on the ground with the tent door facing down
3. Tie or zip the tent door closed.
4. Peg out the front corners of the tent facing the desired direction. Stretch out the base of the tent by pulling out the back corners so that the wall edges make an exact rectangle. When you are sure you have an exact rectangle at each corner, peg the back corners of the tent.

TENT TERMS

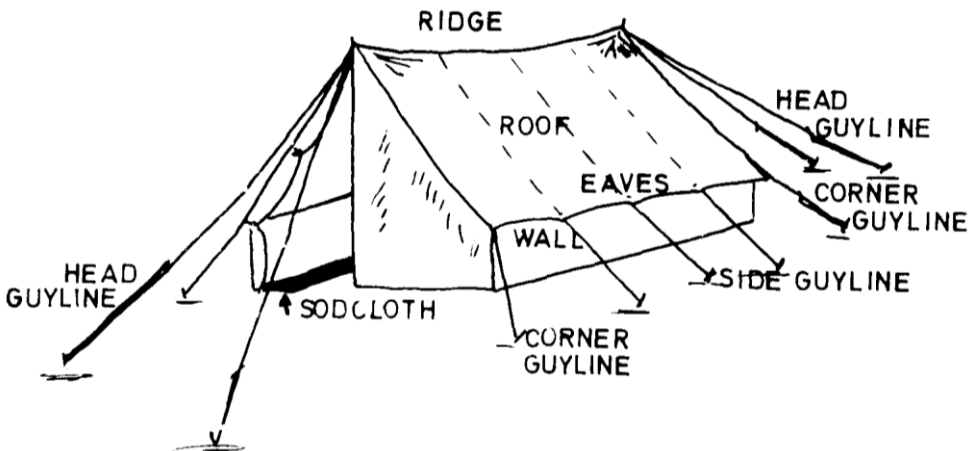



1 PEG OUT FRONT AND REAR CORNERS



2 INSERT FRONT TENT POLE FIRST



3 PEG OUT SIDE GUYS AND BASE OF WALLS LAST

PITCHING SIX-MAN TENT

5. Drive in pegs for the head guylines – those going from the poles front and back.

TENT PEG ANGLES



INCORRECT



CORRECT

6. Untie or unzip the tent door.
7. Place tent poles and ridge pole (if used) in position by pushing the spike of the tent pole through the holes provided in the roof of the tent from the inside. Allow the bottoms of the tent poles to point inwards to be gradually pushed into upright position later.
8. Raise the front tent pole into an upright position and tighten the front head guyline. Repeat the operation for the back pole and head guylines. Make 25mm hollow in the ground at the bottom of each pole.
9. Tie or zip the door closed again.
10. Now peg out the corner guy-lines diagonally.
11. Peg out the side guylines which should be drawn tight enough to keep the roof of the tent from billowing in the wind, but not so tight that they pull the ridge of the tent down. The side guy pegs must be in line with the corner guylines and must run in a continuous straight line with the seams of the tent, running from the ridge to the wall.
12. Make sure that the corner guyline pegs and side guyline pegs are not too near the tent as this will result in the tent drooping at the roof, and the walls hanging slack. Neither must these pegs be too far from the tent as this will result in the eaves curving upwards at an angle forming a channel which prevents rain from draining away) and the bottom of the walls being lifted off the ground.

13. Fold the sod cloth to the inside of the tent.
- 1.4. Drive in a peg at the base of the door for use when the door has to be secured in windy weather.
15. Dig drainage trenches and spread the soil outwards away from the tent fabric. On no account may the soil lie against the tent wall as this causes seepage and rot. See sketch. Remember that trenches are made to carry water draining off the roof and eaves, away, not to keep floodwaters out. Do not cut a vee-shaped trench. Dig straight down close to the wall and then open the trench by making sloping cuts toward straight cut (see sketch), Plan the trench so that it will carry water away from the highest point to the lower ground. At the tent door the trench should branch away at an angle of + 135 to the door, to carry the water away from the entrance. For this reason it is desirable that the ground at the tent door be slightly lower than at the back of the tent.

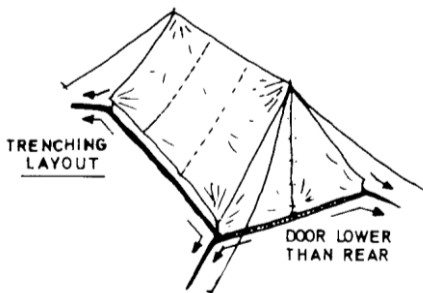
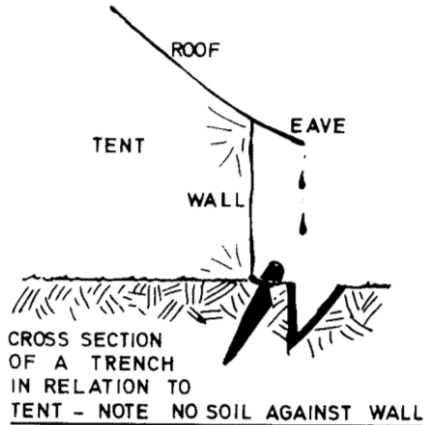

B. ERECTING HEAVY WALL TENTS (PATROL TENTS AND COTTAGE TENTS)

Four to six boys form a team to erect these tents

1. Assemble ridge pole and tent poles flat on the ground.
2. Drive a peg into the ground where front door of the tent is required.
3. Measure the distance with the ridge pole to the position of the back pole and drive in another peg.
4. Unroll the tent and pull it open so that the base of the walls lies along the line between the two pegs.
5. Insert the ridge pole; lift the uppermost side of the tent and push the poles into position. The spiked end of each pole should be in position through the holes in the ridge of the tent. Make a 50n hollow at each peg and position the tent poles with their bases opposite the hollows so that they can slide into the hollows when lifted.

6. Drive in two pairs of pegs, front and rear, for the head guylines, approximately 2m out from the tent pole pegs, so that each pair of head guy-lines will form an angle of + 35 where they meet at the tent pole.
7. Place the head guy-lines in position.
8. Lace up or tie the door closed.
9. Station a boy at each head guyline peg, each holding a head guyline.
10. Other team members lift the tent by the top ends of the tent poles, holding the poles upright while the blokes at the head guy-line pegs loop the head guylines to the pegs. The chaps stationed at the head guyline pegs on the side to which the tent is being raised can assist in raising, by pulling on their head guy-lines, while the chaps on the opposite side keep their head guy-lines just sufficiently taut to prevent the tent from falling over to the opposite side.
11. Peg out the back corner guy-line pegs at an angle of $\pm 135^\circ$ to the wall, in line with the slope of the roof.
12. Peg out the front corner guy-line pegs similarly.
13. Peg out the side guys in line with the slope of the roof at an angle of 90° to the walls, and with the pegs in line with the corner pegs. See s for method of using marked stave for guy-line distances.
14. Peg down the walls.
15. Dig drainage trenches Similar in every respect to those described in the pitching of lightweight tents.

16. Mark guy-lines with white cloth for inexperienced campers who are not accustomed to avoiding guy-lines at night.

Practise pitching lightweight tents and erecting cottage tents many times before attempting to pitch them at camp. Teamwork is important all the time.

C. RECOMMENDED TYPES

1. HIKE TENDS OR PUP TENTS

These are ideal for short camps and if your Troop can afford it, three of these tents should be purchased per Patrol. The tents are light, can be carried easily by one Scout or split between two; one carrying the fabric and another carrying the collapsible poles and pegs. Three small chaps or two big chaps can sleep with ease in a hike or pup tent. Always choose a lightweight waterproof fabric.

2. LIGHTWEIGHT SIX MAN TENTS:

These are becoming very popular; are easily carried if split amongst members of the patrol if they decide to hike to camp; can easily house six big and eight small chaps; have much more head space than pup tents, and are as easy to pitch as hike or pup tents. Ideal for Scout camps. Always choose a water proof fabric; a light coloured fabric for coolness; and a tent with collapsible aluminium poles.

3. COTTAGE TENTS

Usually made of a heavy fabric with heavy rope guy-lines and thick wooden poles. They are far too heavy to be carried to camp by hikers and must be transported by vehicle. They are available in many sizes, the most popular being the 3m x 2m model.

This type of tent is not as highly recommended as the hike or pup tent and the lightweight six man tent.

D. TENTS NOT RECOMENDED FOR SCOUT CAMPS

The Conical Tent., Pyramid tent, and car type touring tent are not very useful at Scout Camps. The worst example of any tent is most definitely the bell tent. It is far too heavy, weighs \pm 50 kgs, is difficult to erect, and never fits rough ground. The numerous guylines are ideal “__tippers” and require too much slacking at night, and tightening in the mornings. The tent is badly ventilated and usually rips or tears at the peak after a few camps. This tent certainly never looks neat and when housing eight big chaps there is enough head arid shoulder space at sleeping time but the campers feet usually have to pile up on top of each other round the tent pole at the middle of the tent.

E. CARE OF TENTS, POLES AND PEGS

1. When unfolding the tent, note each fold so that the tent can be rolled up or folded the same way again when repacked
2. During the day, keep the guylines tight a enough to keep the tent unwrinkled. The head guylines should always take the most strain. Not too tight though, as overtautness cause the pores of the fabric to open and rain then seeps through.
3. Slack off guylines at night just sufficiently to allow for the shrinking of the fabric in the cool evening if this isn't done the tent will tear or the pegs will pull out. If the tent is too slack it will blow down, so take good care when slackening.
4. Do not touch the sides of the tent when it is raining as moisture will seep through the fabric where the tent was touched.

5. Never pack a wet tent. If you have rain till the end of camp, pack the tent temporarily and as soon as you get back to Headquarters hang the tent by its ridge in a spare room or loft to allow it to dry. Never dry it before a fire or heater.

6. Tents should be hung out at the Scout Hall to air for a few hours, after every camp.

7. Just before striking camp a tent inspection should be held. Small holes or tears should be marked, and a note made of damage to each tent so that the tent can be repaired at Headquarters, after airing. See sketch for repairing procedure. It is quite easy to follow.

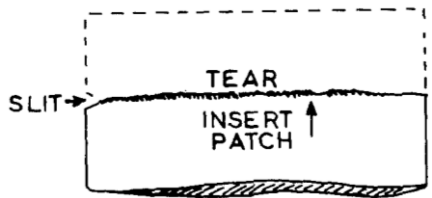

PATCHING A TEAR IN TENT

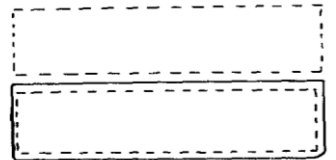

SEW INSIDE AND OUTSIDE

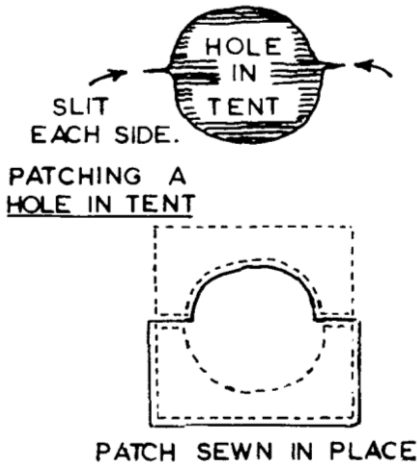

8. If large tears appear in the tent while at camp temporary patch of adhesive plaster from the First aid box can be used to prevent the tear from spreading.

9. Tents should be washed when ever dirty, and mud marks can be cleaned with soft soap and warm water. When washing tents allow them to soak in warm water and soft soap or liquid soap solution for a few hour, then rinse until clean. Oily patches can be removed the same way. Do not scrub tents.

10. Never use harsh soaps, benzene or petrol for cleaning tents
- they dry the natural oils of the fabric and the fabric becomes stiff and brittle. Never boil tents to clean them.

11. Oil wooden tent poles and tent pegs lightly from time to time with boiled linseed oil. Also oil, steel pegs from time to time to prevent rust, which

usually adheres to the tent fabric leaving a mark which cannot be re moved, and often causes rot in the fabric. Make sure that neither poles nor pegs are oily when taken to

camp as this will leave oil stains all over the tent.

Oiling makes the poles and pegs waterproof. This is good at a wet camp where unoiled poles are usually difficult to dismantle once soaked up with moisture.

12. Never pack pegs loose with a tent; always pack in a separate smaller bag. Wash soil off pegs, and allow them to dry before packing.

13. Remove soil, mud etc., from poles and pegs before packing, and make sure that all the pegs are collected after the tent has been lowered.

14. Never hammer the sides of pegs to remove them from the ground. Lever out of the ground with another peg as shown in the sketch.

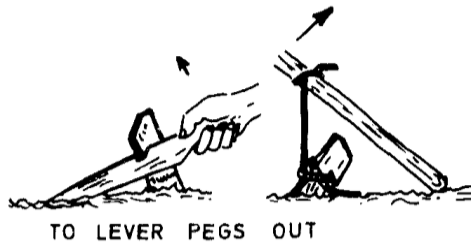

15. Neatly roll all guy lines, as illustrated, before folding and packing the tent. Unrolled guys will tangle and also mark the tent fabric. If your tent has small metal runners loop the guy lines into a 15 centimetre hank and tie off with a half hitch.

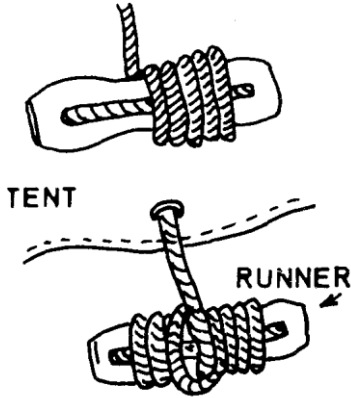

**ROLLING GUY ROPES BEFORE
FOLDING TENT**

16. During camps tents should be aired daily by rolling up the walls of the tents. Attach tapes to the inside of the eaves of your tent to hold the rolled up wall. This method not only airs the inside of the tent fabric but also allows the moisture collected on the ground under your groundsheet at night, to dry.

PUTTING UP THE

REST OF CAMP

Now that the tents are pitched there are dozens of tasks to be done. The following is a guide to camp pitching.

1. Pitch tents.

2. Patrol Leader's allocate sleeping place, inside tents and each boy takes his personal kit to his sleeping place. Absolutely nothing is unpacked.

3.a. In the case of a Patrol camp the Patrol Leader will allocate duties to pairs of Scouts or to individual Scouts, depending on the specific task to be done. These duties would include gathering wood and placing under cover if there are signs of rain; fetching water; erecting a kitchen with gadgets, fireplaces, etc.; unpacking food; preparing tea or a meal, and erecting latrines.

b. In the case of Troop camps the whole Troop would form up at a given signal after all the tents are pitched and personal kit carried into the tents. Thereafter duties would be performed according to the "Duty Roster" on the camp notice board. One whole Patrol might be responsible for wood collecting while another might have to fetch water. Half of one Patrol might have to erect the latrines, while the Patrol Leader and remaining half of his Patrol could assist another Patrol in putting up the camp kitchen if cooking is to be done on a Troop basis with one central kitchen. The Quartermaster and one or two Scouts would see to the unpacking of food and erection of a small "pantry" tent for food storage. Scouts from the wood and water collecting team, after completion of their tasks, could dig refuse

and soakage pits (dry and wet sumps) for the kitchen.

c. In the case of a Troop camp where cooking is done on a Patrol basis with each Patrol having its own little kitchen, the Patrol Leader and one or two of his Patrol could erect the Patrol kitchen while the rest of his Patrol report to the Scout Master for duties as detailed on the "Duty Roster".

The method of cooking on a Patrol basis at a Troop camp should not be encouraged as this wastes too much time. The correct place for Patrol cooking is at the Patrol camp where still better training can be done than at a Troop camp.

In pitching camp remember that a successful camp is a neat camp. It is essential to insist on tidiness, order and discipline in camp. Cooking utensils, tools, axes, first aid boxes, pioneering equipment, fire extinguishers or fire buckets, brooms and every thing else in camp should be placed where it is required most, and where anybody can find what he requires at a moments notice. Hiding an assortment of articles in a rucksack or food box is wrong. Have a proper place for every thing, and make sure that every camper knows where to find the essential things such as first aid boxes, matches, drinking water etc. It would be a good idea for each Patrol Leader to take his Patrol round the camp after pitching is completed, to show them where and how every article is stored.

Pitching a Troop camp (four or five Patrols) should not take longer than four hours at the most, to complete in the finest details. If it does take longer there should be a break for games, a little exploration or adventure of some or other nature lasting at least 1 hour else the spirit in camp will degenerate in a short while.

HEALTH

AND HYGIENE

The importance of a healthy camp cannot be overstressed. As soon as illness in the form of severe colds and flu, or otherwise, gets a grip on your camp your problems multiply.

COLD AND DAMP: Protection from cold and damp is essential. If caught out in the rain without shelter, keep moving. Upon arrival at camp strip off wet clothing, have a brisk rub down with a dry towel and get into dry clothes. Have a hot drink if possible.

BARE FEET: Fresh air and moist grass is good for your feet. Don't be afraid to walk bare foot if you are certain that there are no thorns or scorpions on the site.

CAMP BEDS: A camper's health depends largely on getting good food and sound sleep. Campers will argue on the merits of blankets versus sleeping bags until doomsday. Boys must find out by experiment which suits them best. In SWA sleeping bags are often far too hot in summer and a single blanket is sufficient for comfortable sleeping.

Most people start camping with blankets and pass to sleeping bags later.

In choosing camp bedding, look for the greatest warmth combined with light weight and bulk. The material must dry easily and quickly if it gets wet.

Warmth in bed demands good insulation, that is, dry air warmed by the heat of the body. But the covering must also allow body moisture to escape, else the sleeper will be chilled by the moisture from his own body.

Waterproofed coverings should therefore not be used.

Before discussing bedmaking, let's discuss ground preparation. See that the ground is levelled out and free of stones, twigs, etc. If available, put a 25mm thick layer of straw, dry grass, dry leaves, or very thin twigs on the ground to make a sorter bed. If the above is not available, make shallow depressions in the ground for hips and shoulders. Obviously, the camper must lie down where he intends sleeping, and mark on the ground where his shoulders and hips will be. After making hollows, the camper must again lie down on his side to test whether the hollows are the correct depth. A soil pillow can also be made for the camper's head. (Remember, pillows are not taken to camp).

When once the ground is sufficiently prepared to give the camper a comfortable lying position (on his side) a groundsheet of any waterproof material must be spread over the prepared ground. If your groundsheet has a rubberised surface, place the rubberised surface to the ground. If a groundsheet is not available, a thick layer of newspaper will be as good an insulator.

Ground preparation (hip and shoulder holes) and use of ground sheet applies equally to use of a blanket bed or a sleeping bag.

Bedmaking with blankets is easy. If you use only one blanket during a summer night, place one third of it on the prepared ground and lie down on it. Bring the rest of the blanket over you so that the middle third is on top of you. Roll over slightly and tuck the last third under you. Lift your feet and bring the bottom of the blanket in under your feet.

With two blankets place the left half of one on the prepared ground and the right half of the other blanket over it. Lie down and bring the other halves of the blanket over you, then tuck the bottoms under your feet.

Even better, make a sleeping bag out of your blankets by folding them as above and keeping them in place with large safety pins or blanket pins.

Remember the old camp rule:

Have at least as much under you as over you. In that way you are not only warm against the cool night air, but also against the coolness of the ground.

Blankets and sleeping bags absorb body moisture, and if this is not allowed to evaporate every day the blanket or sleeping bag becomes damp, and after a day or two the camper wakes up feeling cold at night. Air blankets and sleeping bags for two hours daily by throwing them over washlines or bushes (not thorn bushes!). Sleeping bags must be turned inside out when airing. Put them out in early morning when the sun is hot, not late after noon when dew starts early.

Do not use sleeping bags or blanket from your blanket bed. To sit round the campfire at night because the evening dew will make them damp. Use a special campfire blanket for this purpose.

If sleeping bags have been dry cleaned, they must be turned inside out and aired for at least 24 hours, preferably in the sun, before use.

GROUNDSHEET: This is one of the most important items of personal Kit. Use it rubber side to the ground and don't leave it outside in the rain - it must be dry when you need it to sleep on. Air your groundsheet every morning. In the case of plastic groundsheets it is immaterial which side is to the ground as long as the side you sleep on is dry. If you cannot afford a groundsheet, a thick wad of newspapers is as good, and warmer in winter. Do not walk over lightweight groundsheets as stones and sticks will penetrate the material. Army groundsheets, if available, are best as they can be used as raincoats too.

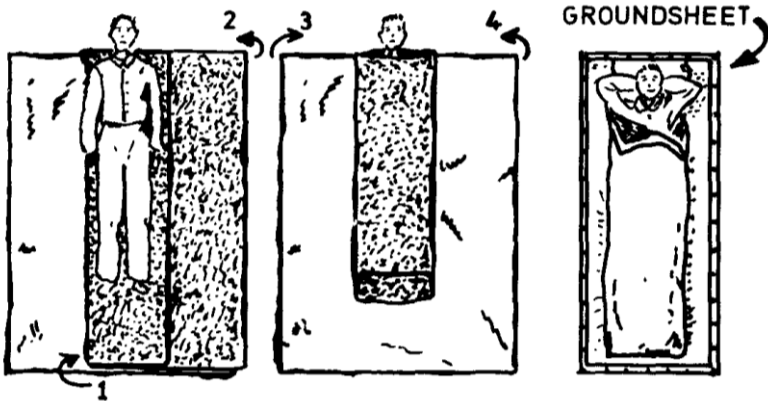

FOLDING DOUBLE BED BLANKETS TO MAKE CAMP BED

CLEAN WATER: Use tap water when ever possible and in the case of farms, use water from drinking water tanks only, with the farmer's permission to do so. Don't drink water from rivers or reservoirs unless you have boiled the water before use. In addition to boiling the water, water purification tablets can be added as an extra safeguard. Water taken from the outlet pipe of a windmill, power— head, turbine pump or hand pump is fit for human consumption, but if in doubt boil the water before use. Spring water coming out of rock is usually pure (rare in this country but definitely seen in the Khomas Hochland.). Don't stir up sediment in a natural spring; use a clean mug to dole out water into a larger container. Should water in a bucket contain a slight sediment, stir a mall quantity of oatmeal into the water or add two teaspoonsful of condensed milk, or add a small piece of alum. This causes sediment to settle. Or strain the water through a mat of grass twisted into a funnel shape. Add char coal which has a deodorising effect, if necessary.



**GRASS FUNNEL
FOR FILTERING
MUDDY WATER**

A well, 50 centimetres square by approximately 50 centimetres deep, can be dug by the side of slow running muddy rivers. The well soon fills up with water which seeps through from the river. Empty the small well three or four times with a mug or billy until the hole is filled with clear water, which can be boiled as a further safety precaution before use.

FOOD STORAGE: Food must be stored in a hygienic manner. Food can be stored in either a food tent: a shelter or natural materials; an underground cool cellar; a wooden box on legs, or a meat safe suspended from a branch of a tree.

The use of a small tent in a shady spot is most popular. This should be out of the kitchen area and near the Quartermasters tent, (nearest to the kitchen if possible), where it can be under constant supervision. A cellar 50 centimetres x 35 centimetres deep, dug into the ground, lined with stones and covered with a wooden cover, positioned on the shady side next to the tent, is ideal for storage of butter, fat, eggs, etc. The ground around the cellar should be moistened from time to time. A smaller cellar can be made by using a larger dixie with a suitable lid and placing the tin in moist ground as shown in the sketch. Keep the soil around the tin moist.

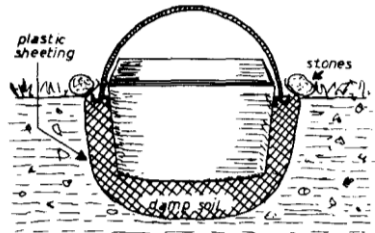

CAMP COOLER
WRAP FOOD IN TIN FOIL
FOR EXTRA COOLNESS,
AND SITE DIXIE IN SHADE



UNDERGROUND
COOLING CELLAR

Meat is best stored in a camp larder or meat safe made of circular pieces of wood and butter muslin as illustrated. The meat safe must be hung in a shady spot where lots of fresh air can circulate through it, and can be hung from a rope running over a branch so that the safe can be lowered when required.

Never store food in paper bags or cartons flat on the ground. Ants, flies, bees and ticks can all get at your food supply. All non-perishable foods are best stored in wooden boxes with hinged lids, which act as table tops, kept off the ground by wooden poles or legs attached to the box. These legs should stand in inverted 750 gram jam tins filled with water to keep ants out.

Sugar, meal, flour, salt, pepper, coffee, tea, rice, oats, mealie-meal, and powdered milk is best kept in large tins with tight fitting lids.

Make a point of wiping the out side of jam tins after use. Bread should be kept off ground and placed in plastic bags or covered with a cloth. Always use "yesterday's" loaves first.

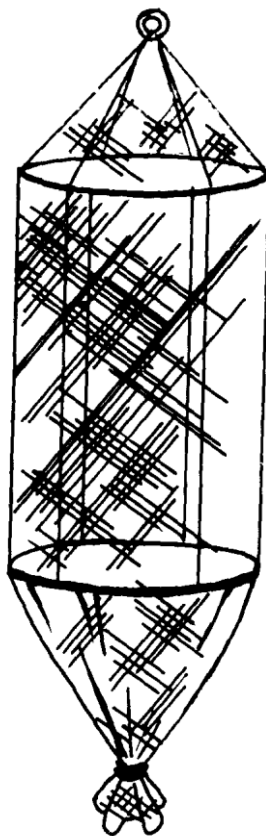

HANGING SAFE
using butter muslin

Potatoes should be kept spread out on top of a bag on the ground with a light cloth covering them, or packed loosely in a wooden crate - not left in a bag.

Fresh milk can be kept in the cool cellar but should not be kept in a closed milk can. Open the can or bottle and spread butter muslin over the opening.

Condensed milk is best left at home as it always attracts ants, flies, and Scouts. Powdered milk is the safest and most easily stored milk to take to camp.

Never store soaps, candles, brushes, ropes, poles, nails, tools, etc., in the food storage tent. These articles of hard ware are kept in the Quarter master tent.

Food storage tents, shelters, etc., are for the storage of food only, and even matches do not belong in the food tent. The food tent is out of bounds to everyone except the senior cook on duty, the Quartermaster and Scouters.

Nobody ever sleeps in the food tent.

WASHING FACILITIES People often think that it is quite in order to walk around camp dirty and with uncombed hair - roughing it, they call it. Scouts just don't do this. A shower can be erected in camp quite easily with the use of a jam tin hammered full of holes, suspended from a branch, with a larger tin containing water, hanging slightly higher than the holed tin. This second tin has a rope attached so that, when pulled, the tin will slowly pour its contents into the holed tin, showering water on the bloke down below. There are many other methods of constructing camp showers.

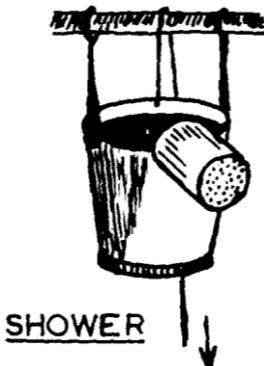

Everyone in camp should wash or shower daily. An area obscured from view behind bushes or trees if possible, should be reserved for this, else the whole camp area will be one mudpatch after a few days. Suitable drainage furrows and pits should be made at the "bathroom", with a "bathmat" of twigs, grass or light sticks. The floor of the shower can be stone lined or covered with wooden slats. In winter hot water makes washing more pleasant. The accompanying sketch shows how a hot water unit can be made.

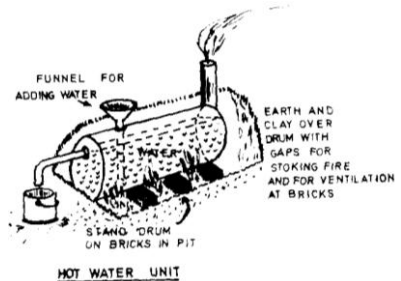

Use drinking water for brushing teeth, and use river, well or reservoir water for body washing. A can (milk can is excellent) of drinking water marked "for teeth" should be placed in the bath room for this purpose. A mug must be available with which to pour water from the can into a boy's mug or a washbasin.

If soapy water is allowed to spread across the ground it attracts flies, makes mud, and kills vegetation. Make certain that all water drains into wet sumps. The construction of a wet sun is illustrated elsewhere in this manual.

Camp wash stands, as illustrated can be quite easily made,



SIMPLE WASH STAND

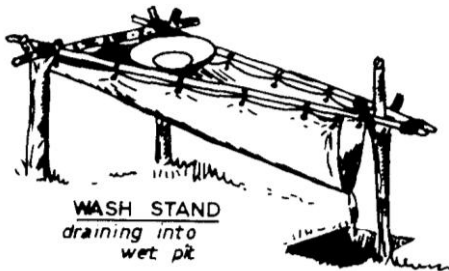

WASH STAND
draining into
wet pit

A mirror should be hung in the camp "bathroom" for hair combing, shaving, etc. Bigger blokes who shave, and Scouters, must shave daily. They are no example to the rest of camp if they do not shave, as there is little that looks more untidy than a man with stubble of beard. And don't use camp as an excuse to start a beard, away from your pals might laugh at you.

SANITATION: This is unfortunately a weak point at most camps. Scouting is the ideal movement for training the generation of tomorrow to stand on its own two Legs. Let the sanitation aspect, which is a necessity to the end of any person's days be an important part of training at camp.

In camp the "lat", short for latrine, takes the place at the toilet at home. This should be situated in a well obscured position behind trees or bushes about 50 meters but not further than 100 meters from camp. Not further because boys have the habit of dodging behind bushes if the distance to the lat is too far. The lat should be to the leeward side of a camp and certainly not near the food tent or kitchen. A screen of hessian or sacking can be erected around the lat for privacy of the occupant, and a supply of toilet paper must be available at the lat in a tin or similar container to keep it dry and out of the sand.

Inside the lat screen, pits should be dug in a line, each about 1 meter long by 25 centimetres wide by 50 centimetres deep with soil heaped up behind the pit. The pits are used squatting with one foot on each side. A more elaborate type with seat can be made from staves. An empty jam tin cut to the shape of a shovel, can be placed upright on each heap. Immediately after use the user should spread soil into the hole covering everything so that flies cannot get at the contents of the lat. The shovel should be placed upright on the heap of soil after use so that the next user can find it easily. A lat should have a separate urinal pit 50 centimetres square by 1 meter deep half filled with stones. Grass is not spread across this pit and soil, is not spread over the stones after use. The stones permit drainage and no water will be visible to attract flies, etc. Another type of urinal is also shown.

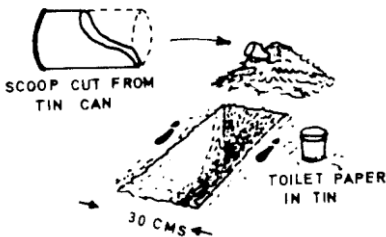
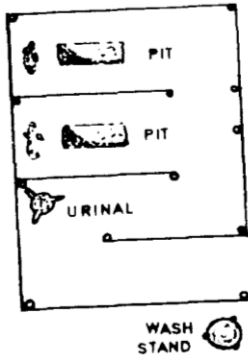
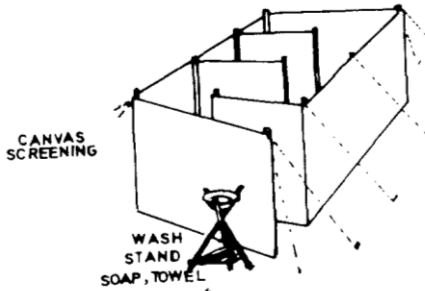

TOILET LAYOUT



Powdered lime or other disinfectant is not thrown into lat pits at camp as this kills the natural bacterial action of all excreta.

When the pits are filled to approximately 15 centimetres from the top they must be filled in with soil, and other pits must be dug. Before filling in the pits a layer of charcoal or ash from the campfire should be scattered in the pit as this helps to purify the ground. After the pit is filled in, a 'taboo' sign, a diagonal cross lashed to an upright pole, should be implanted over the filled in pit to indicate that the area is unclean.

The Scoutmaster or Assistant Scouter must inspect the lats daily.

WET AND DRY PITS: Wet pits are for dirty water from the kitchen; soapy water from the "bathroom" and any wash water whether fatty or otherwise. It is a hole 50 centimetres square; about 75 centimetres deep, with a layer of small stones at the bottom followed by three successive layers of stones each layer slightly larger than the previous one. Then comes a layer of twigs or thin sticks, with a final layer of grass right on top. The

Layer of grass catches up the fat in kitchen water, and allows fat free water to run down to between the stones from whence it drains into the ground. The grass layer is removed daily and burnt.

Wet pits are usually situated as follows One just outside tile kitchen washing place; one at the washing place where each camper washes his plates; one at the camp "bathroom". The quantity depends upon the amount of campers. Taboo signs are erected after filling in these pits.

Dry pits are similar except that they have no stones or grass in but have a heap of soil nearby with a jam tin shovel for spreading soil over everything that is thrown into the pit. No decaying matter should be placed in a dry pit - only old tins, etc., after they have been through the camp incinerator.

One fairly large dry pit, which should be sufficient for the whole camp, is situated fairly near the kitchen. Refuse is never burnt in a dry pit.

All camp pits whether wet or dry, must be roped off and have a taboo sign erected on one corner posts round the pits. All pits are filled in at the end of camp, and taboo signs left over the filled in pit.

CAMP INCINERATORS These are easily made from an old bucket punched full of holes, or stones packed in a circular shape to a height of approximately 50 centimeters with a few 15 cent lengths of round iron crisscrossed across the incinerator about 15 centimeter off the ground. All, decaying matter, meat Scraps. vegetable peels, sweetpapers, tins, etc., are thrown into the incinerator which is set alight immediately after disposal of garbage into the incinerator Usually everything burns except the tins, but when once the tins have been completely burnt out they are flattened and thrown in

the dry pit. Ash from the incinerator is also thrown into the dry pit.



OLD OIL DRUM
INCINERATOR
holes in side & bottom

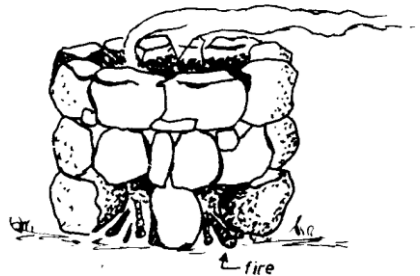

INCINERATOR BUILT
OF STONES

The camp incinerator should be the leeward side of the camp kitchen about ten meters or even further from the kitchen, roped off and with a taboo sign. This is usually the second last item to be dismantled at the end of camp as all remaining garbage and refuse is burnt just before we depart and after the whole campsite has been certified clean by the scoutmaster. The last pit to be filled in is the dry pit into which even the stones of the incinerator are thrown.

THE CAMP

KITCHEN

–GRUB” (food) in camp is most important. Badly prepared food weakens a strong boy more than the hardest work can do. Camp food must be clean, nutritious and properly cooked.

Persons working in the camp kitchen must be absolutely clean, and a wash basin filled with

clean water should be in every camp kitchen so that the cooks can wash their hands whenever necessary. The inside of cooking pots must always be clean and scoured each time after use. This rule must be strictly adhered to even though it is a bind to scour pots and pans. If this is not done food cooked in a dirty saucepan will stick and burn round the dirty spots. Kitchen utensil inspection should be held after every meal to ensure cleanliness.

KITCHEN LAYOUT The kitchen should be so situated that smoke does not drift across to the food tent and the tent lines, and should be roped off so that boys cannot run through the kitchen as they wish.

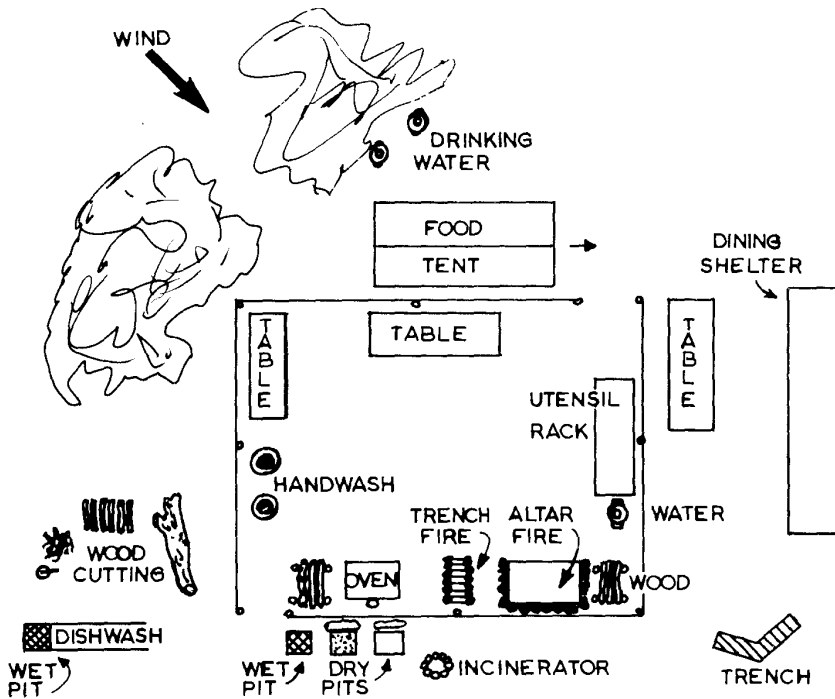

KITCHEN LAYOUT

All the necessities of a kitchen should be grouped close together. Water must be handy; wood must be stacked in various sizes near the fires. An awning or shelter of some sort should be erected to give shade from the sun if tree shade is not available. Above all, remember that the kitchen must be situated so that the fires get sufficient wind. A wash line should be just outside the roped off kitchen, where dish cloths can be dried. The food tent, with back to the wind, should be near to the kitchen but outside the roped off area. A wet pit, or perhaps two wet pits, and a dry pit should be to the lee ward side of the kitchen just outside the roped off area. There should be two entrances to the kitchen one, the main entrance near the food tent, and one at the back of the kitchen near the wet and dry pits, in such a position that firewood can be brought into the kitchen through this entrance.

The roped off kitchen area is out of bounds to everyone in camp except the cooks on duty for a particular meal, the Quartermaster and Scouters.

AXAMANSHIP; Boys going to camp must not be permitted to use an axe, saw or knife at camp if they have not been instructed in the use and safety precautions thereof, prior to going to camp.

The bit of an axe and the blade of a saw must be covered at all times when not in use, and axes and saws must be carried and used according to laid down safety precautions.

A few safety precautions are detailed below:

- a. See that everyone is well clear of the swing of the axe when held at arms length, and not immediately ahead of or behind the axe.
- b. Cut downwards and away from the body. The users' own legs must be clear of the danger line, particularly when using a knife, while seated.
- c. Cut on a block, which should be fixed in the ground for steadiness.
- d. See that the area is clear of all branches, or obstructions which could deflect the axe.
- e. When cutting light timber or sticks rest them flat on the block and steady the stick with the left hand. Do not cut leaning sticks.
- f. When splitting sticks, place the stick flat on the block and cut from the further end.
- g. When sharpening the end of a stick, rest the end on block, and cut downwards onto the block.
- h. Remove loose clothing, lanyards, etc. before using an axe.
- i. Do not stand on a stick to cut it the axe bit cuts into the ground, and this soon spoils the edge.
- j. When tree felling, remember that the tree stem rebounds when the treetop hits the ground. Stand back.
- k. When trimming branches, cut from the under side, with the grain of the wood.
- l. Never throw axes or knives, and never play with them.
- m. Keep a knife closed and an axe sheathed when not in use. An axe temporarily out of use should be masked in the cutting block.
- n. If it is necessary to carry an unmasked axe, grip it close to the head with the blade downwards and outwards, on the side away from your companions.

The care of axe, saw, and knife is important. Before going to camp, all axes, saws and knives should be sharpened. A carborundum stone should be taken to camp to sharpen the items regularly. A blunt axe or knife is more dangerous than a sharp one. The haft of the axe should be kept oiled, both when in use and when stored. The head of an axe must be firm on the haft, and the wedge must be secure. All this must be checked, and if necessary repaired, before and during camp. Regular inspection of these items by PLs and Scouters is essential.

The hinge of a clasp knife must be oiled. Only clasp knives are allowed and the use and carrying of sheath Knives at camps or on hikes is prohibited.

Use these tools only for cutting wood. An axe is not meant for use as a hammer, nor should a knife be used as a screwdriver. Do not hammer a knife into wood, and do not use either an axe or a knife for digging.

Axes, saws and knives are to be cleaned of bark sap, rust, etc., every time after use, and lightly oiled.

A handaxe is used with one hand only, and is held at the grip of the haft, i.e. not near the head.

A felling axe is used with both hands. Do not force the axe down into the wood. Just swing the axe with speed, and let the weight of the head do the cutting. The cutting blow should be given at an angle of 45 degrees to the grain of the wood, making a wide vee-notch.

Deliver the blows alternately from right and left. Do not change hands. Stand well braced with feet apart. Practise until you can hit the same spot every time.

When using a felling axe, two main strokes are used. The first stroke at 15 degrees to the trunk splits wedge-shaped chip. The second

stroke should be as near horizontal as possible, and severs the first chip. Continue until a wide deep kerf is cut out of the one side of the trunk, to a depth of two-thirds the diameter of the trunk. Then commence cutting another kerf on the opposite side of the tree trunk, to a depth of one-third the diameter of the trunk, the second kerf is slightly higher than the first kerf. When the tree starts swaying, stand well clear. Never attempt to fell a tree against the wind. The first deepest kerf is therefore always cut on the downwind side of the tree trunk. Commence cutting the sill of the first kerf at a height above the ground equivalent to the diameter of the tree.

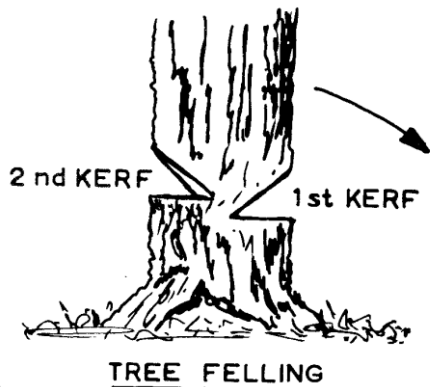

KITCHEN GADGETS At camp we have no ready-made tables, wash- ups, shelves, ovens, etc., as it would be impossible to transport all the goods and chattles of the modern kitchen into the veld. To substitute for these requirements we make camp and kitchen furniture out of available natural materials such as branches of trees for table legs and table tops; forked branches (mikstokke)

to hold crossbars or tables, or as braavleis forks; pothooks for lifting saucepans off the fire, and many other –GAOGETS” as we call, them. A gadget has no fixed design, shape or material. It is made of any available material to serve a particular use in camp and makes camp life as pleasant and comfortable as the model home back in town.

The usual camp kitchen gadgets are as follows;

1. One or two tables and a bench.
2. A pot rack or shelf to keep all pots and pans off the ground.
3. A shelter to keep the sun off the cooks neck.
4. A washup where the pots and pans can be scrubbed.
5. A firewood holder.
6. Pothooks and saucepan litters.
7. Long forks.
8. Box ladders to keep the sun off food already prepare for cooking.
9. Ovens and various fireplaces.
10. Cooks washstand.
11. Drying stand or washline.
12. Fire fans and fire tongs.
13. Chopping block for meat.
14. Chopping block for axe, near firewood.
15. Fire screen in case of strong wind or rain.

All, or most of these gadgets are illustrated in this handbook. Practise making them before camp as they do take time and patience when made the first time.

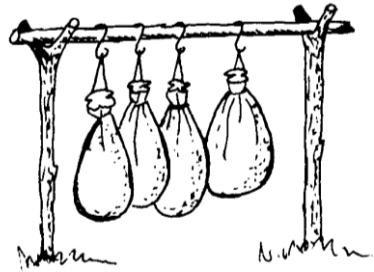

UTENSIL BAGS
ON RACK

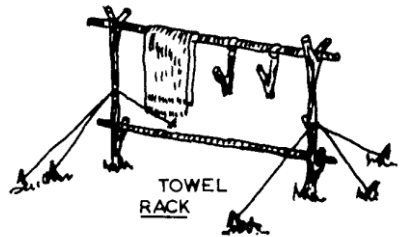

TOWEL
RACK



SHOE
RACK



CANDLESTICKS

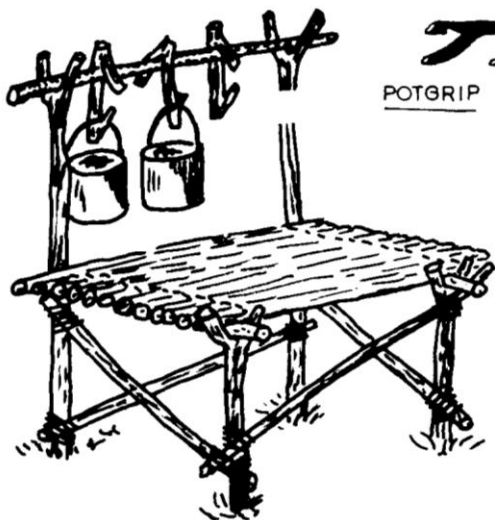

CAMP TABLE

POTGRIP



BRAAI FORK



FIRE TONGS



CAMP BROOM



POTHOOKS



TENT-POLE COATHOOK

BRAAI ROOSTER



POTFORK



FIREFAN



COATHANGERS

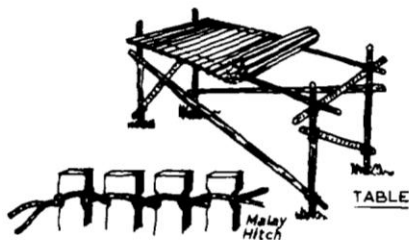

TABLE

COOKING UTENSILS There are so many different types of cooking utensils on the market today that a word of advice should be given. Often we are too weight-conscious, and insist on taking light-weight cooking utensils to camp. Weight definitely is a major factor when going on a hike camp and the best kitchenware for a hike is a Gilwell canteen (a set of two light weight aluminium saucepans with a lid that can be inverted to form a frying pan) But Gilwell canteens, or their bushveld equivalent- a 750 gram coffee tin with lid and wire handle, are ideal only for hikes and perhaps for Patrol Camps. They certainly are useless at large camps or wherever communal kitchens are used. Light-weight cooking utensils usually are too thin for large cooking fires and the contents of such utensils, especially when cooked in large quantities, usually burns.

For Troop camps or camps where food is cooked in large quantities, the old oval Army dixie is ideal. Large three gallon sauce pans, preferably steel, are ideal but a square or "D" shaped pot should never be used as food collects in the corners burns easier in the corners and generally gives a cook and pot scrubber grey hairs before he has completed his job.

Do not use enamelled saucepans, pots or pans in camp as when once dropped the enamel splits off. Thereafter the utensil is virtually useless for cooking purposes as the enamel keeps on peeling off, the more the utensil is used. Cooking pots of retinned iron are ideal and those made of a thick aluminium are as good.

Thin aluminium saucepans or cooking pots should not be purchased.

Then choosing utensils make sure that the lids fit easily and that the handles are strong and preferably not handles of bakelite, wood

or similar material that can be destroyed by fire. The semi-circular bucket type handle is most suitable as the cooking pot can be easily lifted off the fire this way. Use pothooks to lift the pot. Make it a rule when using cooking pots, to always lay the lid of the pot on the ground or table with the outside of the lid to the ground.

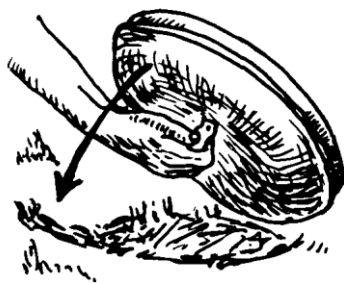

PLACE OUTSIDE OF LID ON GROUND

Frying pans should be of iron but aluminium ones can be used if your cooks are able to keep them sufficiently greased and correctly heated while using them, else eggs, etc., will usually stick in them. Here the "hotplate" cooking method described later, is best, as the heat is spread evenly over the surface of the hot plate. If possible purchase frying pans with collapsible or removable handles to simplify packing.

The following is a list of utensils usually required per Patrol for a weekend camp.

- 2 -frying pans
- 1 -bread knife
- 1 -ladle or large spoon
- 1 -tin opener
- 1 -kitchen knife
- 1 basin (not enamelled)
- 1 -handaxe

- 1 -spade
- 2 -dishcloths
- 1 -tin scouring powder
- 2 -large mugs
 - Butter muslin
- 1-large fork
- 2 -cooking pots big enough for whole patrol
- 2 -rolls thick or heavy quality tin foil
- 1 -bucket (not enamelled)
- 8 -fire irons each 35 centimeters long.

The quantity of utensils for a Troop camp depends entirely upon quantity of boys attending camp. The following is a guide for a camp of four Patrols.

- 5 x Army type dixies or similar 20 liter pots
- 4 x large frying pans
- 3 x bread knives
- 3 x large spoons or ladles
- 2 x tin openers
- 2 x kitchen knives
- 6 x large basins (not enamelled)
- 4 x handaxes
- 4 x spades
- 10x dishcloths
- 6 x tins scouring powder
- 2 x large mugs
- 3 x large forks
 - Butter muslin
- 6 x rolls heavy tin foil
 - 35 centimeters width
- 6 x buckets
- 4 x 45 liter milk cans for water with lids.
- 20x 50cms fire irons
- 4 x large kettles
- 2 x large washing tubs galvanised
- 4 x Bushman saws
- 4 x rakes
- 2 x yard brooms

CLEANING COOKING UTENSILS

This is generally a much loathed task, but one of the most important jobs in camp.

Always have a 20 liter pot of water on the fire for this purpose. Water must be hot, not lukewarm, and there must be plenty of liquid soap and scouring powder available for the task. Cooking pots and all kitchen utensils should be cleaned as we finish using them. There is nothing more disheartening than a mountain of utensils to be cleaned after a meal.

Utensils are not cleaned inside the kitchen itself but at the rear of the kitchen near a grease pit (wet pit) for that purpose. A table of natural materials should be available to scrub on, as scrubbing on the ground is not ideal. If possible, have a large iron basin with hot water and plenty of soap, to scrub in, and a basin of cold water to rinse in afterwards. Dry utensils after use. Do not rely on the sun and wind to dry them for you. All kitchen utensils, pots, pans, etc., are washed and scoured inside and outside and especially in the corners of the handles where dirt always collects.

When utensils are perfectly clean and dry they should be placed on the kitchen racks ready for use again, and preferably covered with an old clean sheet or large cloth to keep as much dust as possible off the utensils.

A hint to remember is to fill pots with water immediately after use so that the food scraps can soften.

Remember to wash dishcloths immediately after use. There is nothing more unpleasant in camp than filthy dishcloths.

Use woodash and sand if you have no scouring powder at camp. With a little water added, woodash and sand cleans a pot as well as any cleaner.

Remember not to scour enamelled pots with steel wool when cleaning.

Porridge pots and rice pots should be washed with cold water until most food particles have been removed. Hot water can be used to do the final cleaning. Hot water tends to make the food particles gummy if used in the beginning.

To prevent cooking pots from getting blackened on the outside they can be moistened and rubbed with a soap layer on the outside before putting them on the fire. But the best preventative method is to use the "hotplate" system of cooking which is explained under "cooking fires". The metal plate over the fire allows only heat to pass through the cooking pots. All flame and smoke is spread under the plate and the cooking utensils are never blackened. But remember to clean the metal plate before packing, else all kit near the metal plate will be blackened.

COOKING FIRES: Numerous sketches of cooking fires appear in the manual. Those sketched are best suited to our country.

- A. "TRENCH FIRE": This method does not work so well in sandy areas. The walls collapse easily but lining the trench walls with flat stones will remedy this. See that the trench front opening is facing the wind with the back downwind. The trench can be wider in front tapered to the rear. Place fire irons across the top of the trench.

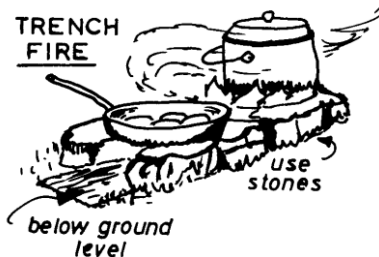

- B. "ALTER FIRE": The sketch gives you a good idea of the design of this type. This method stops backbending and stooping the cook normally has to endure when cooking on the ground. A must for all camps longer than a weekend.

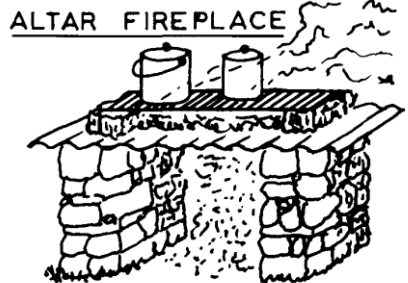

- C. "HOTPLATE FIRE": The most ideal cooking fire for any camp. Consists of any fireplace, "trench" or "altar" with a metal or thick tin plate approximately 38 x 75 cms, placed over the fireplace and supported by stones underneath. Or a fire can be made on the ground, a row of stones packed either side as in the "brick-wall" type with the metal plate over the stones. The fire is stoked from the ends. The whole plate is heated over its full surface and becomes an ideal surface for placing pots on as well as for cooking flapjacks on if a piece of bacon is rubbed

across the surface when hot. The front opening of the fireplace must face the wind with the rear downwind.



- D. CRANE FIRE: Suitable for hike camps or where individual cooking is done - otherwise unsuitable.

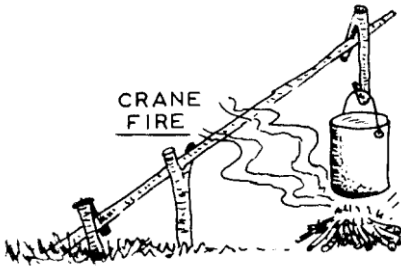

- E. FRAPPER'S OR HUNTER'S FIRE:
Reasonably suitable for Patrol camps, but removing suspended cooking pots is rather clumsy if pot hooks are not fitted on the cross bar.

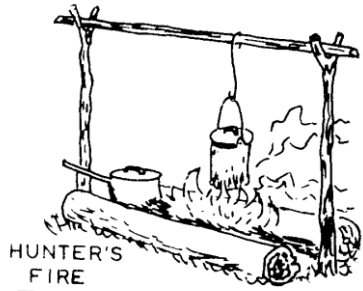

- F. CAMP OVENS: Many versions can be tried at camp. The “bowl oven” illustrated is the simplest form but a deserted ant heap makes a wonderful oven if a large hole is cut horizontally into the ant heap, with a perpendicular chimney at the back. Similarly, the top of the ant heap can be levelled off, a hole made at the base and fire made inside the ant heap. A small chimney at the rear end allows a draft through the ant heap. Heat is circulated through the thousands of miniature tunnels inside the ant heap and the whole ant heap becomes almost red hot giving sufficient heat at the levelled off top for cooking to be done.



There are dozens of cooking fires that can be experimented with. Don't use only those illustrated in the manual, also design your own.

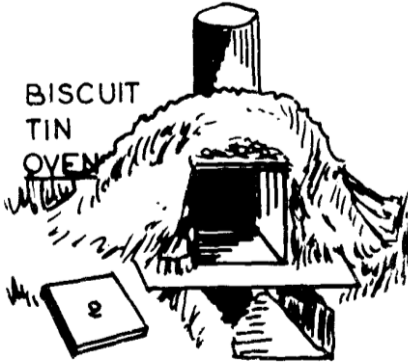

BISCUIT
TIN
OVEN



BACKLOG REFLECTOR FIRE

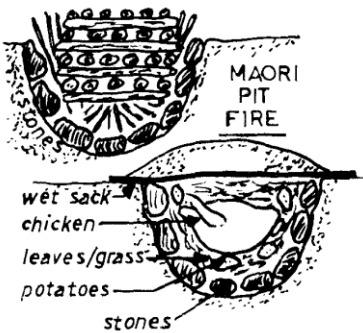

MAORI
PIT
FIRE

wet sack
chicken
leaves/grass
potatoes
stones

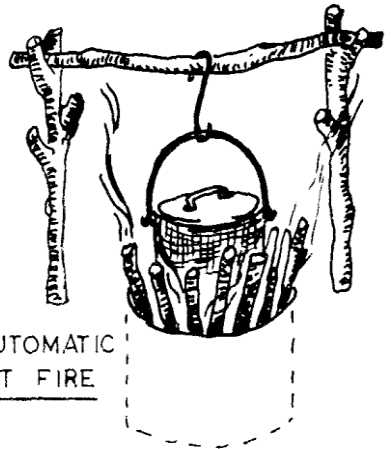

AUTOMATIC
PIT FIRE

All cooking fires are cleared out after each meal; the ash buried and the fireplace thoroughly cleaned. It is advisable to have two or three cooking fires in a large camp kitchen. Keep a small fire burning continuously where a pot of water should be kept at the boil for first aid, etc. Other fires are lit from the master fire which should not be allowed to die. But this fireplace too must be cleaned daily by removing the most ash after the coals have been tilted on a spade and later returned when the fireplace is clean.

Always have a good supply of firewood available, stacked in various sizes near to the cooking fires. Stakes can be driven into the ground and wood packed between the stakes. Cutting firewood into suitable sizes is not done in the kitchen but outside the roped-off kitchen. Only ready trimmed wood is brought into the kitchen and stacked. A handaxe is kept handy for small trimming work, but the chips must be picked up. Always have a supply of wood in the kitchen for two major meals so that cooking can continue in case there is an unforeseen delay in collecting of wood. Have a shelter available where wood can be packed in case of rain. A good supply of tinder for starting fires must always be available in the kitchen, kept under cover in the rain season

HOW TO LAY AND LIGHT A FIRE

Break up small Sticks approximately 2mm in diameter to about 15cms in length. Lay a foundation or platform of sticks about 25mm thick and 30cm long. This will allow a draught to get underneath the kindling which is placed in the centre of the platform. Kindling is very thin wood or sticks about 1mm in diameter mixed with dried grass seed or crushed grass, which will ignite very easily. Round the kindling build a little pyramid of the thinnest of the 2mm thick

twigs mentioned above. Place the twigs round carefully and not too close together. Keep building another layer of twigs round the one underneath, steadily using thicker twigs until you come to a last layer of twigs 10mm in diameter. Light your fire from the windward side. Strike the match, shield it in your cupped hands to give it a moment to light properly, and push it carefully into the kindling. As soon as the pyramid is well alight, feed the fire with more twigs, giving the flames sufficient fuel without choking them. After about 5 minutes the fire should take logs of 50 mm thickness, which will make good coals for cooking

Keep your cooking fire small. Too Large and too hot fires always burn the food, and "cook the cook".

Always have a good supply of wood handy so that there cannot be a shortage halfway through the meal preparation.

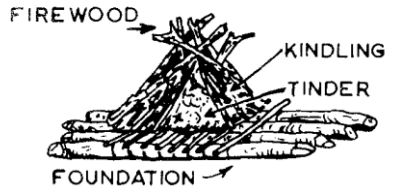

STARTING A FIRE

When lighting a fire in high wind try the protective lo method below.



LIGHTING A FIRE IN HIGH WIND

In rainy weather it is often not easy to find dry wood to start a fire. Obtain a deadwood log. Split the log down to the dry centre and cut off several, thin lengths of dry wood from the centre, approximately 25mm in diameter. Whittle shavings from this dry wood with a knife to use as kindling, leaving the shavings attached at one end. These are called fuzz-sticks. Using fuzz-sticks and short lengths of dry timber from the inside the log, you will have no difficulty in starting a fire. Thin wet wood can be added once the fire is burning, and steadily thicker wood can be added once the fire is burning well.

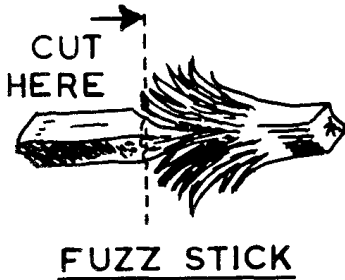

A good hint for a firemaker is to have a gadget called a "blow-pipe" available. Take a 50cms length of approximately 10mm diameter plastic or rubber tube, and insert at one end an 8cms length of copper or steel tube. Slightly flatten the protruding end of the copper or steel tube to make a narrow longitudinal hole. Hold the copper or steel end of the tube near the base of the fire and blow down the plastic tube. In this way you can restart a fire which lies dwindled down to only a few glowing embers. With the aid of a few dry twigs added to the embers while you blow, you can quickly induce sufficient flame into your fire to get it restarted. If nothing else is available a hollowed out reed will do the job as well.

BURNING PROPERTIES OF VARIOUS WOODS

Local woods are better known by their native or popular names and for this reason it has not been attempted to translate the name of the wood.

- A. "KAMEELDORING": Gives good hard coats but takes so long to burn out, and also so long to really burn well, that this type of wood is best used in large camps where lots of time is available for firemaking. The wood does not give off much heat when burning, due to its slow combustibility. Best used for campfires but not recommended for hasty cooking fires. Also very tough and hard for handaxes. Does not light easily and can usually only be added to a well burning fire of another wood.
- B. "SWARTHAAK OR HAAKBOS" This wood is similar to the Kameeldoring wood in almost every respect from a burning point of view. The wood is difficult to cut as the bush is always covered with thousands of hooked thorns. Makes good coals but takes almost as long as Kameeldoring wood to burn to coals. Does burn faster and therefore has a better flame and heat for cooking purposes. Does not burn to ash. Makes little smoke. This wood is not highly recommended for camps.
- C. "HAAK EN STEEK" OR "BINK-BLAAR WAG- n-BIETJIE": Burns well and gives off lots of heat and flame, Very easy to light with the aid of a little tinder. Makes good coals which are not as long lasting as the afore mentioned two types. Usually does not burn to ash.

It is difficult to cut because of many thorns.

If available in sufficient quantities this wood is ideal for camp cooking fires

- D. SOETDORING”, WTTDORING”
OR -MIMOSA”: Probably the best camp cooking fire fuel obtainable but is rather scarce in this country as it has always been known to be very good fuel. The wood is not as hard as Kameeldoring or Swarthaak. It is easily cut or chopped into suitable sized pieces; is easily lit with little tinder, and makes little smoke.

Burns fast with an excellent flame and good heat for cooking. Makes good coals which last quite long before turning to ash.

If you can get it, Soetdoring is by far the best wood for cooking fires.

- E. WITGATBOOM” AND
GEELHOUT”: Witgat is readily available but Geelhout more abundant in the East of South West Africa. Both woods burn extremely well when dry and make very good coals. Unfortunately the coals do not last long but the heat of the fire and the flame is ideal for fast cooking. Almost too fast. You have to keep stirring the contents to prevent food burning when using these two types of wood. The coals quickly die to ash, and one drawback is that your fireplace always overflows ash as so much wood has to be used. The ash, if not careful, invariably ends up in the food.

Geethout has no thorn and has a yellowish coloured bark with many shiny leaves. The tree is the only yellowish looking tree in the Territory - hence it’s name. Does not grow into a

very high tree and is usually found in sandy areas in the Kalahari.

The Witgat has thorns and a white and sometimes gnarled stem. Does not grow into a high tree - more a .high bush than a tree.

Both are ideal woods for cooking fires, especially for the hiker who needs a fast fire.

- F. BLUEGUM, POPLAR AND PINE”:

All suitable for quick fires as they have a certain turpentine content.

They flame well, light easily, make little or no coals, give off lots of heat, but if used, large quantities are required for camps. Not readily available in South West Africa.

WET AND DRY PITS: Already a much discussed subject but is such an essential part of your camp that it is only proper to mention it in this chapter again, so that it cannot be forgotten when setting up the camp kitchen.

INCINERATOR As above this has been described in full in the previous chapter but is mentioned again as that it won’t be forgotten when planning the kitchen.

COOKING WITHOUT UTENSILS: The Backwoods method of cooking eliminates the use of utensils entirely. There are so many various ways - cooking mealies in their leaves on coals; cooking potatoes and sweetpotatoes on the coals; making dampers on hot stones or coals; twists on sticks; kabobe on Sticks held over the coals resting on two upright forked sticks; frying an egg in an orange peel or boiling it in a half orange without removing the fruit of the orange, or boiling it in a paper bag of water held over a Fire, or poaching it inside a hollowed out potato.

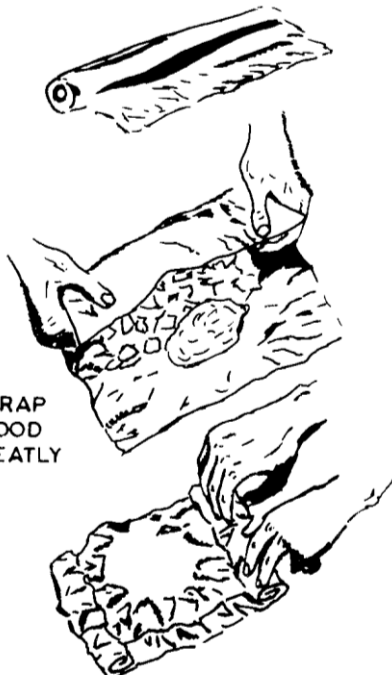

WRAP
FOOD
NEATLY



COOK OVER
COALS

ALUMINIUM
FOIL COOKING

Tin foil cooking is done without utensils and is one of the most popular methods of fast cooking for small camps or hikes.

Grilling meat on coals is such a standard practise in this country that it need hardly be mentioned. Better known as –braaivleis” it can be prepared on a wire grid made at camp, or just placed on the coals. It tastes better grilled flat on the coals.

These are methods not usually adopted at a large Troop camp but certainly can be standard procedure at a weekend Patrol camp and hike camp.

Without practice a camper can never expect to have success with Backwoods cooking. The old saying is that –God sends the food and the devil sends the cooks” and this is definitely so with Backwoods cooking if never practised before camp or hikes.

FIRE SRELTFRS OR SCREENS These are often used at camp under very windy conditions. An awning of canvas can be erected if it rains, or a screen of hessian, sacking, reeds, thatching, wood, or any thing that will prevent your fire from being blown out, can be erected.

I all cases make 100% certain that the flames can not possibly reach the screening or shelter, no matter how experienced the cook may be.

MENUS

AND MEALS

This chapter should be all about recipes: what to cook at different types of camps: how to cook, etc., but all this information can be obtained from mother at home or from books like –Outdoor Cooking” by Lone Wolf, or from –Backwoods Cooking” — Patrol Book No 17, and dozens or other cookery books available in the Scout shop.

Knowing how to prepare food isn’t all that counts in cooking,

Knowing what to cook is vitally important and menus should be scientifically approached - not just cooked up on the spur of the moment.

To maintain the body in good health, especially at camp where everyone works hard and plays hard, daily food should contain protein for body building; fats, starches and sugar for energy and mineral salts and vitamins for protection from disease. The diet must contain sufficient calories (heat production) or energy providers, but if the protection foods (vitamins) are neglected the diet will not be balanced and will be unsuitable for campers no matter how filling or bulky the food may be.

The bulky energy providers such as bread, potatoes, sugar, etc., must be supplemented by inclusion of the following foods:

- Vitamin A - dairy produce, carrots, tomatoes.
- Vitamin B1 and B2 - whole grain, rice, spinach, tomatoes,

- eggs, liver.
- Vitamin C - fruit, oranges, lemons, grapefruit, fresh vegetables, cabbage.
- Vitamin D - milk, butter, dried fruits, liver.

Whole foods, such as brown bread, brown sugar, brown rice, should be used in preference to refined, devitalised products. Fresh fruit, vegetables and meat should be used in preference to tinned goods.

Among the protein foods select eggs, cheese, fresh meat in preference to bully beef and other tinned meats.

If some of the boys don’t like brown bread or brown sugar, strike a happy medium by handing out white and brown bread, or adding brown sugar to one large pot of tea or coffee instead of having a sugar tin filled with sugar passed around for each Scout to help himself.

The camp programme must be taken into account when planning a menu. Don’t have a heavy meal before a swim or hike or hectic afternoon, as this tends to make Scouts lazy. Have a light lunch. Swimming on a full stomach can often be dangerous and must be avoided.

The programme should be so arranged that work such as collecting wood and fetching water, is done before breakfast to build up a good appetite. Never have a skimpy break fast in camp. Have a large well balanced breakfast of stewed fruit, porridge, bacon and eggs or sausage and eggs, bread, butter and jam and coffee or tea (not both). Other cereals can be introduced in the place of porridge if the boys dislike the latter. An ideal breakfast which contains all the required vitamins, proteins, iron etc, is –Fop Form!! or –Pro

Nutro". It is quick to prepare and easy to serve. A high bulk breakfast of this type is sufficient, and nothing else need be served except tea or coffee.

Then have a light lunch - perhaps a tin foil "zombie" (a potato, tomato, carrot, onion and a piece of sausage banged together in tin foil with a few fineries added) and an apple and coffee.

A good supper or soup (even though the boys don't like soup much) cheese and potato fritters with fried eggs and coffee or tea, should be served.

Instead of teas in the morning and afternoons, fresh fruit drinks are much more popular. Have plenty of fresh fruit in camp, and at least once a day fresh fruit should appear on the menu.

If a starchy dish such as macaroni and cheese is served, a light desert like fruit salad should follow to balance out the starch

Similarly a thick substantial stew is often welcome at supper time after a light sandwich lunch, and is better than another meal with a lot of bread.

It should be an unwritten law in camp that any gift of sweets, cakes, etc. should not be eaten in secret by the boy who receives the gift, but shared by the whole camp. It is often said that midnight feasts should be banned, but seeing that the boys do get quite a kick out of these feasts there is nothing wrong with permitting them, on condition that all the snacks are pooled so that everyone can join in the fun. Scouters should not be present unless specifically invited and even then should stay for only a few minutes.

Boys' should not be permitted to eat sweets etc., between meals and must definitely not be allowed to bring tins and tins of canned

fruits, sweets, cooldrinks, etc, to camp as they will feast on these in private and only nibble on the well balanced diet you have arranged for them. A good way of stopping the practice of bringing extra food to camp is to have kit inspection immediately upon arrival at camp the first day. Confiscate all the fancy eats and hand them over to the Quartermaster who will supplement the camp rations with all those extras. This will happen once or twice, but not again. After a few camps repeat the performance.

QUANTITIES After preparation of the menu, quantities must be worked out with care. It is better to overestimate than to run short of food. Left-over food can usually be used in a stew, rice pudding or otherwise.

Insufficient food soon leads to grumbling and to attempts to bring in food from outside.

On the other hand, if fancy dishes like crawfish tails or likkewaan toes are listed on the menu the result will be the same - better "Scouty" food will be brought in from outside.

The following list of minimum quantities per boy per meal will serve as a guide when deciding how much food must be taken to camp:

Butter	— 35g
Flour	— 56g
Eggs	— 2
Jam	— 28g
Oats or mealimeel	— 42g
Potatoes	— 168g
Honey	— 21g
Prunes	— 55g
Fresh vegetables	— 168g
Biscuits	— 4
Dried fruit	— 56g
Powdered Milk	— 28g
Cheese	— 56g
Rice	— 28g

Fresh Fruit	— 1 item
Breakfast Cereal	— 56g
Sugar	— 84g
Tomatoes	— 112g
Meat	— 224g
Tea per day	— 10g
Lettuce	— 56g
Sausage	— 168g
Cocoa per day	— 10g
Provita biscuits	— 56g
Bacon	— 42g
Pepper and salt	
Coffee per day	— 14g
Fresh milk	— 300ml
Bread	— 280g
Rice	— 42g

Provita biscuits or dampers can replace bread as they are less bulky to carry during hike camps and Patrol camps.

Note the following which may also assist in your food planning:

A measure of “One Cupful”, as given in ordinary household recipes, is not so practical as we don’t, as a rule, have cups in camp. We refer therefore to “one small mug full” instead of a cupful.

HERE’S A USEFUL HINT; An empty condensed—milk tin (which is about the size too of a small mug) holds exactly what the housewife’s recipe books call a standard “cupful”. So, if you want to be dead accurate — use a condensed milk tin!

A measure of “One Teaspoonful” means a level teaspoonful. The same with a dessertspoonful or a tablespoonful- it’s a level measure

To get it accurate, fill the spoon with the ingredient — then scrape off level with a knife. (Same with a cupful- scrape it level with a knife). Here are some other useful rule-of-thumb-measurements

2 cups (2 level condensed-milk tins)	1 pint or ,56 litre
4 cups (4 level Condensed-milk tin)	1 quart or 1,12litre
2 tablespoons of any liquid	1 ounce or 28gm
2 tablespoons of butter, level	1 ounce or 28gm
4 tablespoons of flour, level	1 ounce or 28gm
1 cup white sugar (1 level condensed-milk tin)	6½ ounces or 185gm
1 cup brown sugar (1 level condensed-milk tin)	5 ½ ounces or 156gm
1 cup flour (1 level condensed-milk tin)	4 ounces or 113gm
1 cup mealie meal (1 level condensed-milk tin)	4 ½ ounces or 128gm
1 cup oatmeal (1 level condensed-milk tin)	4 ½ ounces or 128gm

ONE- 5½ kg leg of mutton will do for about 24 - 30 campers, if served with other food.

340g of tea or coffee will serve 25 to 30 people.

340g of cocoa for 35 people.

When planning the quantity of food to be taken to camp, first work out your menus estimate the number of days you will be in camp, or on the hike, and the number in the party - then the number of meals involved. List the Breakfasts, Lunches and Dinners and work out a menu for each. Multiply the number of campers by the weight of food listed above, per person. Add 15% for the hungrier-than-usual types, and your quantities should be correct.

Consider conditions under which you will be camping- winter calls for different food from summer, for example; ask your self whether fresh milk, eggs, meat and so forth will be available near the camp- or whether you have to take every thing with you. Consider facilities for keeping food fresh - no good considering fresh meat or milk, for example, if it's going to go "off" through lack of keep-fresh facilities.

Consider cost, of course. When you have worked out your menus, you can estimate total requirements, get prices. Then, if you see the cost is too high, you can make adjustments, change some items, and reduce costs. When you have finalised overall costs, you can let each camper know what the food plus other expenses, such as travel, will be. Be careful not to under estimate. It's a good idea to add 15% to your estimate - then refund each camper if there's any money left over after the camp, and pay out a "dividend".

Remember that the way food is served in the mess tent is as important. If dished up in a slovenly manner with dirty utensils and ladles, the campers will soon pull up their noses. The cleanliness of cooks hands, utensils, kitchen, mess tent, campers plates and cutlery all go hand in hand with the camp diet. If anything along the line is not as it should be, appetites will not be as they should be Campers will go hungry become listless and moody, and the ultimate summing up of your camp in their own words will be "we starved".

Camp's a place for training, and test and badgework. It is important, when planning the cooking programme, to look at the Patrol Progress Chart and include foods, and kinds of cooking, that will assist training and test passing needs of the moment.

Hike rationing and meal-planning is a special game, a lot different from planning for a Standing Camp. The same goes for canoe cruising and other ventures Weight of food and containers is a vital consideration. Food preservation is another important factor. How much do you take and how much do you plan to buy along the route. Where are trading posts located, and will a store be open when you arrive there? Shall we just take a 24 hour emergency ration, and buy main supplies along the route? Is there fire-wood available along the route, or will we have to use Esbit pocket stoves or other light, portable cooking equipment? How about utensils? It makes a big difference to hike rations if you're cooking without utensils, or mainly in foil alone. These are the kinds of things you have to think about when you plan food and cooking for camps, hikes, cruises, mountain expeditions and canoe cruising.

DAILY CAMP**ROUTINE**

Apart from all the jobs to be done immediately after arrival at the campsite, such as wood collecting, water fetching, lat building, etc., we must remember that there are dozens of small jobs to be done daily. Water must still be fetched once or twice a day. Similarly, wood must be collected, trimmed and stacked; pits filled in and new ones dug; pots scoured; tents perhaps patched; storm water ditches dug, and many more. All these duties must be so arranged that the camper does not start thinking that he is in camp to only work and have no play. He must play as much as he works, and when we say "play" it could mean learning something new about pioneering; building a newly thought-up large gadget involving various lashings and knots, etc. To the boy this is all play. Using a spade or pick or axe for one hour is interpreted as a day's hard work by the same boy.

Work must be included in the daily routine so that it is hardly noticed as work. Bring in a game or swim or meal or anything else that will break the monotony of work for a while. A specimen programme is detailed below to give you an example of how busy and enjoyable a normal day at camp can be.

**A SUMMER CAMP HELD IN MARCH
IN SOUTH WEST AFRICA**

05h30 Camp rises, bedding and tents aired, wash and ablutions.
06h00 P/T for five minutes, then a swim.

06h30 Cooks on duty, wood and water—fetching and general camp cleanup as per roster.
07h30 Preparation for inspection.
08h00 Breakfast and further inspection preparation.
08h45 Flagbreak and prayers.
09h00 Inspection and Change back into working clothes.
09h20 Practical training in axemanship- P/L Instructors each with own Patrol.
10h00 Game- "stave hockey".
10h30 Troop instruction "The Compass", cooks on duty.
10h30 Break for cooldrink.
10h20 Pioneering — each Patrol to make one of the following:
1. Scout transporter.
2. Water seasaw.
3. Foofy slide.
Using all the knots up to and including Pioneer Award on the project.
12h30 Lunch - followed by rest in shade.
14h30 Demonstration in checking depths of rivers for bridge building- done at dam.
15h00 Game - "stone Circle" - very active.
15h15 Preparation of kit for 3km night compass march.
15h30 First Aid practical- Mouth-to-Mouth Resuscitation.
16h15 Break for cooldrinks.
16h30 Session on self defence with demonstration.
17h00 Wood and water-collecting, cooks on duty.
18h00 Swim and life saving practice
19h00 Supper and cleanup, also preparation of campfire by duty Patrol.
2h00 Depart on night compass march.

- 21h00 Informal campfire.
- 22h00 Cocoa, prayers and bed.
- 22h15 Lights out and quiet in camp.

This programme includes two hours of actual hard work, cutting wood and carrying water, apart from extra work like cook duties, pot scouring after meals, and others. But there is always something pleasant after the hard work, and in both cases the work is shortly before a meal to build up their appetites, (and also arranged for the cooler part of the day). Wherever there is a little inactivity in the programme it is followed by something active, even if only in the form of a game. Whatever instructional work has been done has been revised later, e.g.

- i. "Compass" in the morning followed by a compass march at night.
- ii. Depth checking of rivers to be followed by the building of a bridge across the river the next day.
- iii. Mouth-to-Mouth resuscitation followed by life saving practise later, and so on.

The argument might be that from 10.15 p.m. to 5.30 a.m. is too short a sleep for a growing boy, but in this country it is best to start early. Lay off at midday as is done for 2 hours in the above programme, when all can have a short sleep when the day is at it's hottest. Then work a little later at the end of the day when it is cool.

Keep your programme filled to capacity, as energy filled boys want to be kept busy all the time. As soon as they sit around with nothing to do and plenty of time to do it in, they find time to moan and grumble. If your programmes are interesting and fun packed,

the boys will never complain about it being too full a programme.

However, moods can change, little things can go wrong in camp, and for this reason the Scouters must always have an alternate item or two up their sleeves, to substitute a dull item on the programme in case this becomes necessary. Remember that programmes must be "elastic"

FLACBREAK AND INSPECTION

Flagbreak is a means, but not the only way, to start a day. Whenever the programme allows, flag break should be formal, with all in full uniform. All campers should attend. However, if the programme is such that the boys will be leaving on an expedition early, and immediately after flagbreak, it would be unwise to insist on uniform for flagbreak. Flagbreak, if correctly done might be seen as demonstrating outwardly an aspect of duty to country and respect toward our Scout flag. The National Flag is not flown at camp.

Flagbreak is the opportunity for prayer for the day, instructions in respect of the programme, presentation of camping standard penants, etc. The ceremony of flagbreak should be simple, smart and sincere. There is nothing more discouraging than to take part in a casual ceremony which lacks both precision and sincerity. However, we must avoid an approach that is so rigid that it loses personal touch.

Flagbreak is not done at sunrise, but is usually done at a fixed time, e.g. 08h00, after breakfast. The flag must, however, be lowered punctually at sunset every day. Tradition demands that the sun does not set on a hoisted flag.

In contrast to flagbreak, the lowering of the flag is not necessarily a ceremony. If so decided, all campers can form up at the flagpole, but usually only the duty PL is present at the flagpole. At sunset he sounds the “freeze” on his whistle. Every one, irrespective of where they may be, stands to the alert, and the flag is lowered. The PL sounds the “defrost” on the whistle, and all campers go on with whatever they were doing before. Nobody be in uniform.

The question “why inspect?” often arises. Campers inevitably wonder why inspections are necessary. The inspection should be used as a means of encouraging high standards of camping. Inspections should always be short, friendly and helpful. If criticism is necessary, make sure that you also comment about something encouraging as well, and that Your reasons are understood. Points should only be awarded in small quantities for specific details e.g. poor, average, good. Competition should encourage, and never discourage. Do not over-emphasize results or let them get out of proportion. Points to note are:

- a. Is each camper happy and rested?
- b. Is the camp and it's campers clean and hygienic?
- c. Is equipment being Stored and maintained safely and properly?
- d. Are all the campers in possession of their own personal effects?
- e. Are appropriate items being dried/aired/washed as the case may be?
- f. Would the camp be improved by some additional item of equipment such as an extra large tent for wet weather activities, or new tents, or better axes, etc.?
- g. Are there any immediate problems in the camp that need solving?

In fine weather it is preferable that all personal kit be placed outside the tents, but in wet weather the kit can be packed out inside the tent. The campers groundsheet is spread open outside the tent and his personal effects are packed out on the groundsheet as detailed in the sketch.

PERSONAL KIT PACKED OUT FOR INSPECTION

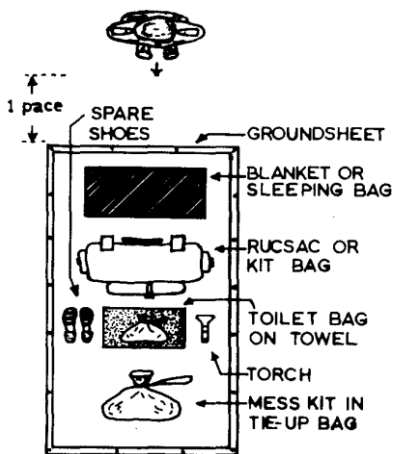

Damp clothes or towels must not be put in rucsacs- they should be placed on the Patrol washline to air.

All litter, bits of string and rubbish should be collected from inside and round tents, and disposed of in the fire or dry pits. Any lost property found should be handed to the camp Quarter master for later identification.

During inspection each camper stands at the alert behind his personal effects. If a Scouter is doing inspection he will inspect the Patrol Leader first, who will

thereafter accompany the Scouter during the real of the inspection.

All tent walls should be rolled up and tied up before inspection. After inspection the tent walls should be left rolled up to enable the tents to be well aired and the ground to dry, for at two hours. After inspection blankets and sleeping bags should be aired for at least two hours for reasons already mentioned.

If the camp is left for any time, for example during an expedition, etc., all kit should be placed inside tents and the walls dropped and pegged down, with tent doors properly closed- it is prefer able to leave one or two persons in camp to keep out two and four legged inquisitives.

It is preferable that Patrol Leaders do their own Patrol inspection, but Scouters must inspect regularly to ensure that standards remain high. There are occasions When the Scout master will have to carry out some form of inspection simply to give himself an opportunity to advise on, and encourage, better standards of camping.

It is vital that the boys under stand why they are being inspected and that it is to their own benefit that hygiene standards, general tidiness, etc., is insisted on.

It is wise to introduce penants on a daily floating trophy basis for certain standards achieved. There could be a penant for the neatest Patrol; the Patrol with the least illness or accidents or losses of equipment; the fittest Patrol; the Patrol with the most points; etc., etc. The required standard must be raised daily, and if none of the Patrols come up to the required standard for inspection for example, the penant is not awarded on that day. The Patrol winning a particular penant for the day is entitled to hoist the penant below the Patrol flag in the Patrol area, or if Patrol flags are all hoisted next

to the main flagpole, then the penant may be hoisted there together with the recipient's Patrol flag



14

CAMPFIRES

—Camp without an evening campfire is like home without a mother — something missing, something lost.”

But gone are the days of fantastically organised campfires with cheer leaders stamping around looking daggers at the boys because they are not singing loud enough or not being active enough, and songs being stopped in mid-verse because it has just struck 21h43 and the programme says that the —Dassies” will present their Patrol stunt at 21h43.

A campfire was originally intended to be a happy band of youngsters sitting round a fire of warmth and cheer, a fire round which men of all ages have sat and deliberated, or made merry, according to desire, When two or three are gathered together

round a fire the spirit of companionship embraces all. If permitted to do so of it’s own accord, words flow, reminiscences flood to the mind and old songs spring to the lips.

Let the song we sing be clean, traditional, old or new, but away with vulgar and highbrow songs. Let the fire purify the mind, let comradeship be your guide.

A planned campfire programme is something of an art gained by experience, and is fine for a specific celebration, special occasion or parents’ evening. As this seldom applies to camps, this is all that will, be said about highly organised and fantastically planned campfires.

The campfire we are interested in at camp and thus in this manual, is the informal one lasting about an hour every evening after a hard day’s work and play. It is here that the seeds of true companionship are sown. Here we learn to see each other in a different light; can relax and according to our mood sing Or not Sing. This is the place for those campfire yarns to be told by the Scouters or anyone else able to tell a short suitable yarn, (not a tall story), or to praise where praise is due to someone in camp. Here we never directly find fault with boys or things done in camp, but tactfully and companionably discuss our problems, always recalling that the boys did their best but could perhaps do with a little more experience in this or that, if the need arises to request improvement.

It is here that the “Camp Council” can be held - where the Scouters explain the programme for the next day, answer questions or hear complaints. If discussed in a friendly way at “Camp Council-” many little problems can be ironed out and much time saved in discussing the programme of the next day while everyone is relaxed and not all keyed up ready to go it all the way, as would be the case the next morning.

Here we are a lot of pals together irrespective of rank or age, as long as respect to all remains.

Let our informal campfires where we can sit and chat and sing and play whatever musical instrument we have brought along, without fear of a visitor laughing at the mistakes we make

— let them be the reminiscences that will one day flood back to our minds many years after leaving this movement — reminiscences of the happiest days of our life.

STRIKING CAMP

We have dealt with every phase of a normal Scout camp and now come to the last task in camp, yet as important as the first.

Striking camp is also something that has to be prepared. With weekend camps it usually starts an hour or so after the last midday meal in the case of camps near our hometown. The after lunch rest period is usually used for packing personal kit, leaving out uniforms till last. At the time indicated on the programme Patrol Leaders will supervise the removal of their Patrols kit to the loading zone where kit will once more be packed in Patrol batches in the shade if possible. While this is being done the Patrol kitchen (if there was one) would be broken down 2 by two of the Patrol, and the remainder of the Patrol would break down the tent, refold and pack it and assist with packing all other Patrol equipment. The Patrol Leader, when satisfied that his Patrol site is clean and that all Patrol equipment is at the loading zone, would take his Patrol off to the loading zone to report to the Scoutmaster to volunteer for further duties such as filling in pits or lats, packing Troop equipment, etc.

In the case of a large Troop camp with a communal kitchen the same would apply up to and including the Patrol taking all their personal kit to the loading zone.

Thereafter, the Patrol Leader and Second plus two Patrol members would return to the Patrol site to break down kitchen and

tent, and pack and convey Patrol equipment to the loading zone. The remaining three members of each Patrol would report to the Scout Master for duties such as packing Troop equipment, filling in pits and lats, and generally assisting the Quartermaster, who has many other tasks.

Gadget wood, if suitable, could be packed up and taken home for the next camp. If the decision is made not to take gadget wood home it must be burnt out completely before we leave camp.

String, sisal, papers, tins, everything left over must be picked up by the campers moving through camp in a straight line over the full width of camp. All useless items picked up are burnt in the incinerator. There after the ashes, flattened tins and incinerator stones are all thrown into the dry pit which by this time should be the only remaining open pit on the site. Only then is the dry pit filled in.

Taboo signs are left standing if the campsite is one of our regular sites. It way out in the bundus where only animals can see our taboo signs, there is no sense in leaving them, and they too can be burnt and buried.

With long camps the procedure could be slightly different.

On the eve of striking camp all bills should be settled and rent (if any) paid. Check transport arrangements. If departure is to be early in the day a certain amount of cleaning and packing should be done the night before. Scouting gear that will not be needed again can be packed. Fill in main rubbish pits and all latrine pits except one.

The practice of holding a short Thanksgiving at the end of camp is recommended. Perhaps this is best held at the end of the Camp Fire on the last evening. It should be short and simple, and Scouts should be given genuine opportunity to take an active part.

Final inspection of the whole area is done by the Scouters, accompanied by the Patrol Leaders a half hour before time of arrival of our- vehicles at the loading zone. Then everyone changes into uniform, packs camp clothes, closes haversacs and kit bags, and stands ready at the loading zone to load the vehicles immediately they arrive. No more running around, last minute swims, etc.- by this time every boy must be at the loading zone.

The Scoutmaster leaves to thank the owner of the campsite and the Assistant Scoutmaster takes charge of loading of the vehicles immediately on upon arrival.

The procedure of loading the vehicles, embussing from the rear, travelling rules, and debussing at Headquarters again, is the exact same as that detailed in Chapter V, with the exception that what was done last is now done first, and vice versa

ADMINISTRATION

THANKS: Write letters of thanks to all who have helped you in any way.

THE NOTE BOOK Throughout the camp you should carry a note book and pencil with you to jot down ideas for improvement, etc., that may occur during the camp. It is easy to forget these unless they are noted down at the time. This should be kept for reference when planning the next camp and so help you to profit from your experience. In this way you will run better camps year by year.

RECORDS: File copies of correspondence, menu sheets, lists of quantities, programmes, etc., for future reference. Camp logbooks should have been kept by the Patrol Leaders; this can now be finished off and photos added. Collections of photographs and any cine films taken at camp should be available at the next parents' social or Group Annual General Meeting.

SUMMARY

Camping cannot be reduced to just another little subject in the Scout syllabus. There is so much in camping that has not even been mentioned in this manual such as Axemanship, First Aid and dozens of other items that are essential to good camping. Obtain books on these subjects so that your knowledge of camp and all that goes with camping can be complete.

Do not attempt to memorise the contents of this manual. That will not make you a good camper. Instead, work according to the details given in the manual, practise them and most important of all, APPLY THEM

Refer to this manual whenever planning a hike, Patrol camp or any other form of camp, and follow the procedure detailed in the manual. Do not reduce "preparation before camp times" detailed in Chapter II because you think you need less time for preparation. If you attempt to prepare for camp one or two weeks before camp you are bluffing yourself, and will be doing the boys an injustice because your camp will not be well planned.

Only well planned and well programmed camps are a success.

Camping is a great game probably the most exciting event in a boys' scouting life. It is here that Scouters and Patrol Leaders get to know their boys best, and here is where the boys have the most fun, but if camp is not well planned none of this happens. Time, effort and money is wasted and parents and boys object to future camps.

Plan well, practise often and apply the contents of this manual, and your camps will be a great success.

APPENOICES

- A** EXTRACTS FROM –POLICY, ORGANISATION
AND RULES

- B** SPECIMEN PARENT CONSENT FORM.

- C** CAMPER’S _SPERSONAL EQUIPMENT

- D** LIST OF CAMP EQUIPMENT REQUIRED PER
PATROL OF EIGHT SCDUTS.

- E** TROOP EQUIPMENT FOR TROOP CAMP
EXCI.UDING PATROL EQUIPMENT IN
APPENDIX !D

- F** SCOUTER’S PERSONA EQUIPMENT.

- G** CONTENTS OF CAMP FIRST AID KIT.

- H** SUGGESTIONS FOR MEALS.

Rovers intend to visit a site frequently at weekends, a general notice should be given at the beginning of the season.

A

EXTRACTS FROM “POLICY, ORGANISATION AND RULES”

Rule 356:

- i. No SCOUTS may camp without the previous permission of their D.C.
- ii. Only in exceptional circumstances, and with the specific consent of the D.C., may Cubs be allowed to camp with Scouts.
- iii. When SCOUTS propose to hold a camp outside their own District at least 14 days notice of a camp with in their own Area and 21 days notice in another Area, must be given by the Scouter in charge to his D.C. who will inform the Secretary of his Area.

Rule 357: The Area Secretary shall

- a) if the camp is to be held in his own Area, inform the D.C. concerned;
- b) if the camp is to be held outside his Area, immediately advise the Secretary of the Area concerned.

Rule 358: The D.C. of any District in which the camp takes place, has control under Rule 131(8). (Rule 131(8) gives the D.C. the authority to exercise control over all visiting SCOUTS whether camping or not”).

Rule 359: parties of Scouts or Rovers trekking or hiking through one or more Areas should give similar notice, stating approximate dates. If Scouts or

Rule 360: To implement the conditions set out in Rule 356, permit forms can be obtained free by D.C.'s from Area H.Q. Permit forms must include the essential requirements shown on the pro-forma issued from S.A.H.Q.

Rule 361: District Commissioners must only issue Permits to Group Scoutmasters of Groups of whose camping abilities they are completely satisfied and Group Scoutmasters must use the same discretion in issuing permits to Patrol Leaders. The District Commissioner is not relieved of his responsibility as to these camps.

Rule 362:

- i. SCOUTS proposing to camp or travel outside South Africa must first obtain the sanction or the Chief Scout through the usual channels; the application must be accompanied by a recommendation from the D.C.
- ii. Sanction will not be given to Cubs to camp abroad, or, save in exceptional circumstances, to travel abroad.
- iii. Invitations to foreign SCOUTS to visit or camp in South Africa must not be issued until sanction has been obtained from the Chief Scout through the proper channels.

Rule 363: Enough sleeping bags or blankets must be provided to enable each scout to make up a separate bed.

Rule 364: Camp Raiding and other forms or horseplay are strictly prohibited.

The following Rules also apply to camps:

Rule 299: Members of the Movement may, at the discretion of the Scouter in charge, wear any convenient clothing in camp, but whenever they appear in public outside the camp limits, they must be in proper uniforms.

Rule 353: Scouts Bathing:

- i. No Scout shall be allowed to bathe, except under the personal supervision of the Scouter in charge of the party or so competent adult swimmer appointed by him for the purpose. The safety of the place must have been previously ascertained and all reasonable precautions must be taken, including the provision of a life line.

All reasonable precautions should be taken to ensure that bathing does not take place in waters infected with Bilharzia.

- ii. A picket of two good swimmers, preferably those with Rescuer Badge, must be on duty (undressed), in a boat or on shore as the circumstances may demand, ready to help any boy in distress. The picket himself may not bathe until the others have left the water.
- iii. This rule does not apply to bathing in properly supervised swimming baths. The precautions set out in this rule may also be modified to a reasonable extent where the Scouter in charge has previously ascertained beyond any doubt that the whole of the water is shallow, and that no possible danger exists or can exist.

(NOTE: If boating is included in the camp activities read the Whole section, Rules 35]. — 355)

CUB CAMPING and PACK HOLIDAYS are covered by Rules 351 — 365 and by Rule 365 in particular. Exceptions cannot be allowed to the provisions of Rule 365.

NOTE: Reading Rules 356 and together we see that the Scouter should contact his D.C. regarding permission early in the process of arranging the camp. If he leaves it to the 14 days before hand mentioned in Rule 356 he might find permission refused under Rule 361, by which time arrangements might be well advanced. (Pass preliminary information to the D.C. as soon as the camp is under discussion).

B

EXAMPLE OF A PARENT CONSENT FORM

PARENTS CONSENT FORM

To the Scouter,

..... Pack/Troop/Commando

I,

being the father/legal guardian of

.....

a member ofPack/Troop/Commando

hereby request you to allow him to take part in a camp/ excursion at

.....

.....

from..... to

I further request that the Scouter—in—Charge act ~~in~~ loco parentis”

during the said camp/excursion.

In making the request I am aware that although the Scouter will do his/her best to act responsibly neither the Boy Scouts Association nor its Scouter accept responsibility for loss, damage or injury to the person or effects of

.....

which may be sustained during the said camp/excursion.

.....

Father or Legal Guardian

Address.....

.....

Date.....

C

WHAT TO BRING

1. Full Uniform.

2. **PERSONAL KIT:**

All kit to be clearly marked with your name or initials and packed into a Rucksack or Kitbag. (NO suitcases)
Groundsheet.

Sleeping bag AND 1 Blanket or 2 blankets and blanket pins.

Tracksuit or long trousers and very warm jersey.

Warm, Pullover.

Shorts 2 shirts, 2 pairs stockings, spare shoes, underwear.

Bathing trunks. Towel.

Toilet Kit (Toothbrush, soap, etc.)

Handkerchiefs.

Sewing Kit.

Mess Kit in string bag. NO PORCELAIN OR PLASTIC ITEMS
(2 plates, mug, knife, fork and spoon, dishcloth for washing up).

Pocket knife.

Torch and spare batteries and bulbs.

Side Rope 3m x 6

Natureatudy Book.

Pencil, ruler and rubber.

Note Book.

Water bottle.

Survival Kit.

Camp Fire blanket.

Musical Instrument — if proficient.

Do NOT bring any sweets, etc.

D

CHECK LIST OF CAMP GEAR PER PATROL OF 8 SCOUTS

SCOUTING STANDARDS S.W.A. AREA No 3/6.5.74

PATROL EQUIPMENT

- 2 Metal Trunks large enough to hold equipment
- Roll Cal. Book with decorated cover.
- Patrol Log Book with decorated cover size A4 or A5.
- First Aid Kit as per SCOUTING STANDARDS SWA AREA No. 6/6.5.7
- First Aid Blanket (Cheap Grey type)
- 9 Staves 168cm long
- 1 Patrol Totem Stave 168cm long
- 2 Patrol flags (flag to fit Totem Stave)
- 1 Torch
- 4 Spare cells (batteries)
- 1 Plane Table Set (in cover)
Contents
 - 1 Silva Compass
 - Drawing paper
 - Ruler
 - Protractor
 - Pins (NOT DRAWING PINS)
 - Eraser
 - Drawing Brd. 30cm x 45cm
 - 2 Bulldog clips
 - Pencil
- 1 Box Matches
- Pocket knife as specified in Uniform Handbook.
- 2 Pieces of white chalk
- 1 Rescue Rope (3.5metres hemp 15mm diameter)
- 9 Lashing ropes each 3 metres in length as supplied at Scout Shop.
- Whipping twine (supplied at the Scout Shop)
- Scout Trail
- Small Hand Broom Orange Ouster
- Town Map and map or area where camping
- Emergency call up system Patrol Progress chart as supplied by Scout Shop
- Patrol Notice Board site approx 70 x 60
- Small Bible
- Scout Prayer Nook
- 1 Patrol Tent complete with pegs etc.
- 1 Pup Tent - complete with pegs etc.
- 1 Mallet (Metal not wood)
- 1 Aluminium Kettle 3 to 5 ltr.
- 1 Frying pan (medium sized) not enamel
- 1 Bread Knife
- 1 Bread Board
- 1 Sieve (± 15cm diameter) with handle
- 1 Tin opener
- 1 Kitchen knife (Carving type)
- 1 Hand Basin Plastic approx 40cm diameter
- 1 Dishwashable Basin Plastic approx. 50cm diameter
- 1 Hand-axe in Mask
- 1 Bow Saw - with Cover over blade
- 1 Spade (fold up type)
- 2 Dishcloths

- 1 Tin Scouring powder
- 2 Pot Scrapers
- 1 Bottle Dishwashing fluid
- 2 Large Enamel mugs
- 3 Rolls Toilet paper
- 1 Large Kitchen fork
- 1 Large cooking pot with lid
- not enamel
- 1 Smaller cooking pot approx.
30cm diameter { not enamel)
- 2 Galvanised Buckets
- 8 Fire irons — each 50cm long and
1 cm diameter
- 1 Small Enamelled milk can
approx 3 ltr.
- 1 Large Ball Sisal (cooldrink straw
thickness)
- 1 Ball Twin (match-stick thickness)
- 1 Paraffin Tilley lamp (Packed n
shockproof Box)
(NO GAS LAMPS ALLQWED)
- 1 Small Hurricane lamp and spares
for both lamps
- 1 Bottle Paraffin (well packed)
- 1 Small Bottle Methylated spirits
for Tilley Lamp (well packed)
- 1 Roll heavy duty Tin Foil
- 1 Plastic Butter dish nth lid
- 1 Large butter muslin/water
combination kitchen larder
- 1 Eggbeater
- 1 salad grater
- 1 Egglifter
- List of Patrol Equipment in lid of
Metal Trunk
- 20 Grain bags (empty) or
60 sandbags (empty)

E

TROOP EQUIPMENT FOR TROOP CAMP (EXCLUDING PATROL EQUIPMENT APPENDIX D)

SCOUTING STANDARD S.W • A. AREA NO 5/6.5.74

1	Scouter Tent (8 man)	2	Fold up campers chairs
1	Tilley Lam	1	Fold up campers table
2	Hurricane Lanterns large for latrine and ablution area.	1	Portable flag pole- approx 4 metres high.
1	Double latrine complete with poles and pegs etc.	1	Troop Flag
1	Large Braai Rooster minimum size 80om x 150cm.	1	Camping Standard Pennants
20 x 5 metres x 15mm diam Lashing Ropes Hemp and Sisal mixture.		1	Small tent for first—aid tent.
20 x 3 metres x 10on diam Lashing Ropes Hemp and Sisal mixture.		1	Folding stretcher for first—aid.
2 x 30 metres x 30mm diam Hauling Rope Hemp and Sisal mixture		1	Handsiren or compressed air alarm device.
8 x 5 metres Pine Poles.		20	Grainbags (empty or 60 sandbags (empty) Game equipment
8x 3 metres Pine Poles.		1	Troop First Aid Kit
12 x 2 metres Pine Poles.			
	Plain fencing droppers (Anchor pegs and blocks and heavy mallets obtainable from District store for Windhoek Troops Troops outside Windhoek would have to stock their own)		
1	Hand axe in mask		
1	Bow Saw with cover over blade		
1	Plane table set — as set out for a Patrol.		
2	Fold up spades		
1	Hunter type torch and spare cells.		
1	Box Matches		
1	Broom		
1	Orange Duster		

F

CHECK LIST SCOUTER S KIT

- * Uniform
- * Personal Kit
- * Lamp — pressure or electric
- * Prayer book and Bible. Hymn sheets.
- * Torch. (Spare batteries and globe).
- * Stove — pressure or gas.
- * Repair outfit “make and mend” materials.
- * Writing materials
- * Reference books on Training items proposed
- * Postage stamps if necessary
- * Post cards if necessary
- * Personal firearm
- * Maps of area (if available)
- * Compass
- * First Aid personal

G

CONTENTS OF CM FIRST AID KIT

SCOUTING STANDARDS S.W.A.

AREA NO 6 6/6.5.74

KIT PACKED IN SMALL HAVERSACK

- 1 Pr Small Blunt Nosed Scissors
- 1 Pr Small Tweezers
- 1 Needle in cork
- 2 Medium Field dressings ±8cm wide
- 2 Large Field dressings ±15cm wide
- 1 Large Roll Gauze ±15cm wide
- 1 Box of small adhesive strip dressings (Band—aid or Elastoplast all one size)
- 1 Small container (Red) Methiocolate
- 1 Small bottle —Salon or —F.C.P”
- 1 small box —DISPRIN”
- 2 5cm Elastic - Gauze Roller bandage.
- 1 Roll Adhesive strip plaster (without dressing)
- 1 Roll Sofradex eye and ear drops
- 1 Tube Tannafax ointment for burns
- 1 Wt smallest cottonwool ±15cm wide
- 1 Bottle Vicks
- 1 Pkt Safety Pins
- 6 Triangular Bandages
- 1 Bottle Furoxene Suspension
- 1 small Bar of Toilet soap
- 1 Water bottle marked — FOR FIRST AID USE ONLY.

H

SUGGESTIONS FOR MEALS

Breakfast:

Porridge, cereal Bacon, sausages,
boerewors
Eggs- boiled, fried,
scrambled, omelette
Tomatoes- fried or raw
Fruit - fresh Or stewed

Other meals

Soup - Several brands and kinds
available

Fish - Kippers
Haddock
Fish cakes
Herrings in tomato
sauce (tinned)
salmon (tinned)
Sardines (tinned)
Meat Chops
Steak
Thick rib (for stewing)
Mutton, leg (for pot roast)
Beef -boiled or roast
Chicken – pot-roast,
spit or roil cooking
Mince (for mince balls,
fritters, eto)
Sausages, polony,
boerewors
Curry

Vegetables— Potatoes (boiled, chips,
roast, mashed)
Beans (dried, green)
Onions
Carrots
Cauliflower
Peas (tinned, frozen—
packed or fresh)
Sweet—corn (tinned)
Meshes
Rice

Salads—

Lettuce
Carrots (grated)
Tomato
Cucumber

Miscellaneous — Duniplings (in stew)

Macaroni (in stew)
Macaroni cheese
Welsh rarebit

—Afters”— Fresh Fruit

Fruit salad
Stewed Fresh fruit
Stewed dried fruit — prunes,
mixed fruit
Custard (with fruit salad or
stewed fruit)
Fritters
Pancakes
Jelly
Instant pudding — several
makes and types available
Bread, jam, cheese